

Dessin/Drawing 251-1

tuyau flexible / flexible pipe
D intérieur / internal D : 20mm

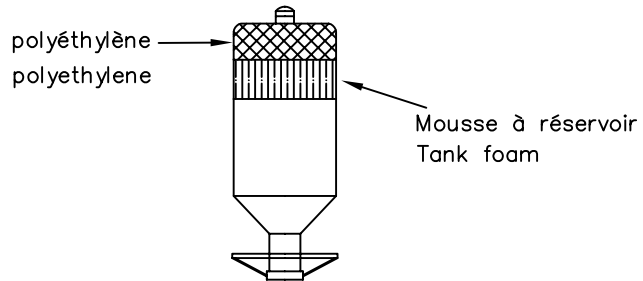
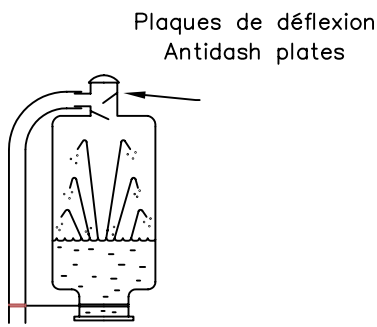

Dessin/Drawing 252-1

Dessin/Drawing 252-2

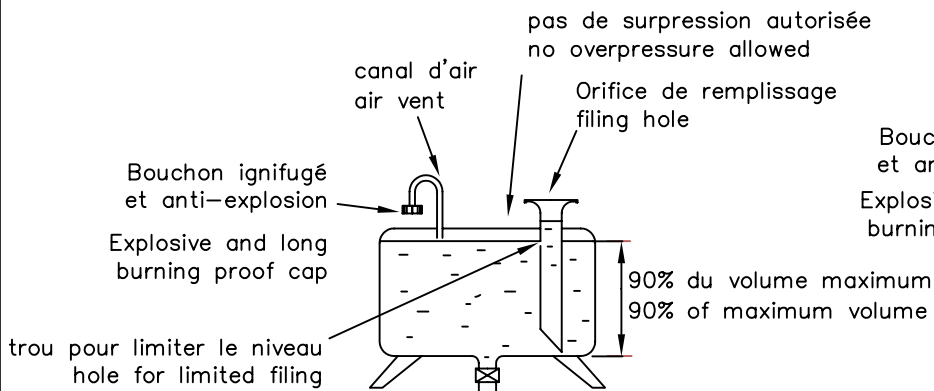

Dessin/Drawing 252-3

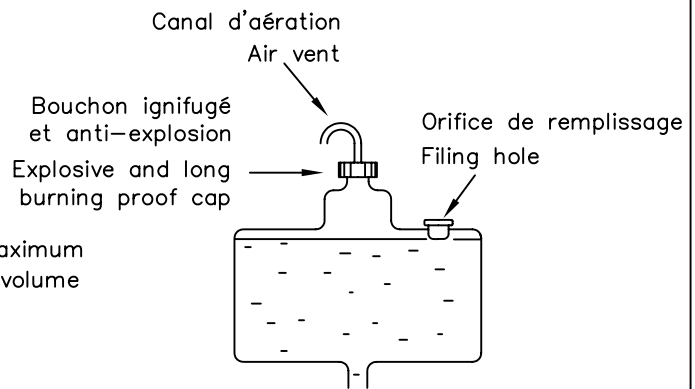

Dessin/Drawing 252-4

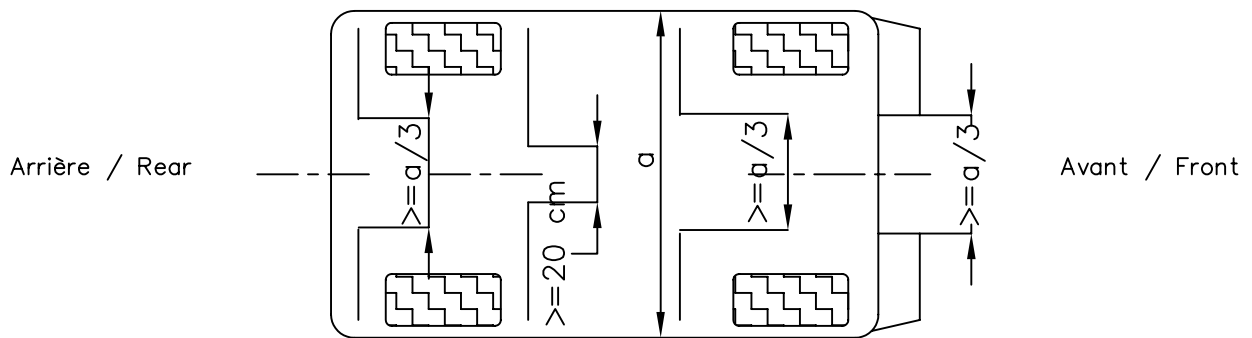

Dessin/Drawing 252-6

	D1	D2	D3	D4	L1
PP20M	2.0"	2.5"	2.25"	3.7"	6.3"
PP20MR	1.5"	2.5"	1.75"	3.7"	6.3"
PF20MS	1.5"	2.5"		3.7"	6.9"
PP15M	1.5"	2.0"	1.75"	3.3"	5.7"
PF30M	1.25"	1.65"	1.45"	2.68"	4.64"
PF40M	1.25"	1.65"	1.45"	2.68"	4.64"
PP125M	1.25"	1.75"	1.5"	2.9"	5.1"

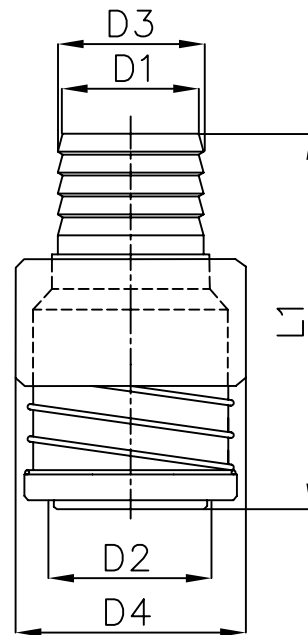

Prise male / Push pull series male

	D1	D2	L3	L4
PP20F	2.0"	2.5"	6.75"	3.25"
PP20FR	2.0"	2.5"	6.75"	3.25"
PF31F	1.75"	2.12"	5.3"	3"
PF41F	1.75"	2.12"	5.7"	3.38"
PP15F	1.5"	2.0"	6.75"	3.25"
PP125F	1.25"	1.75"	6.25"	3.1"

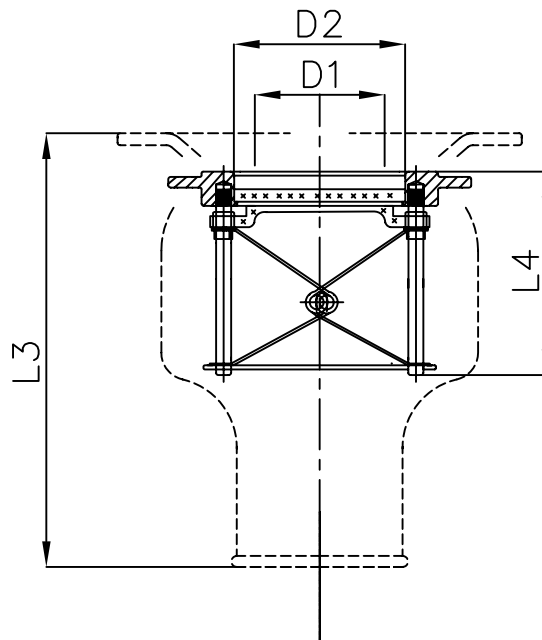

Prise femelle / Push pull series female

Dessin/Drawing 252-5 version A

Montage sur carrosserie
Mounting on bodywork

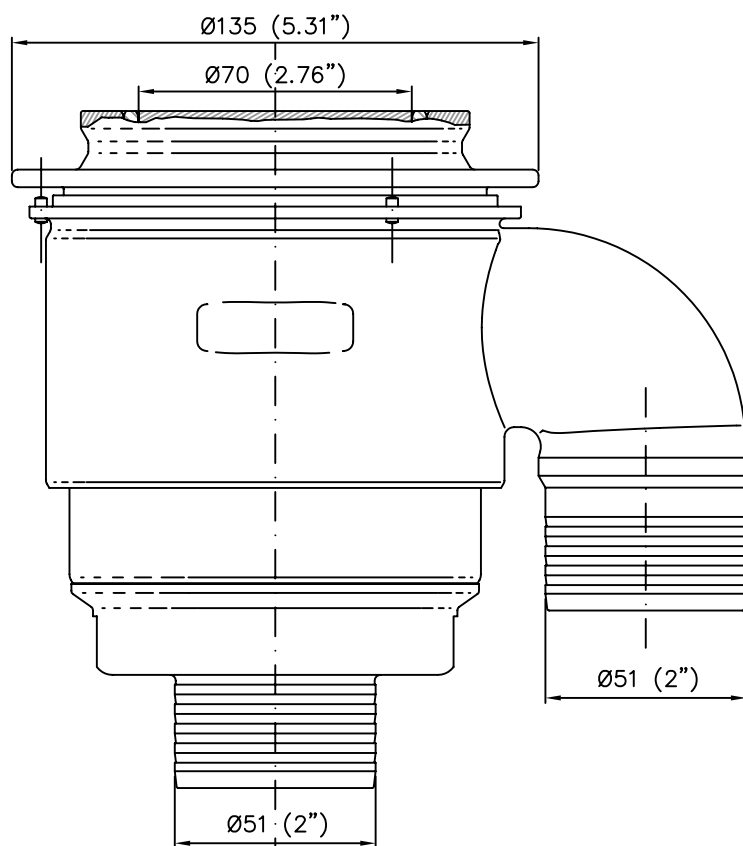

Montage sur réservoir
Mounting on tank

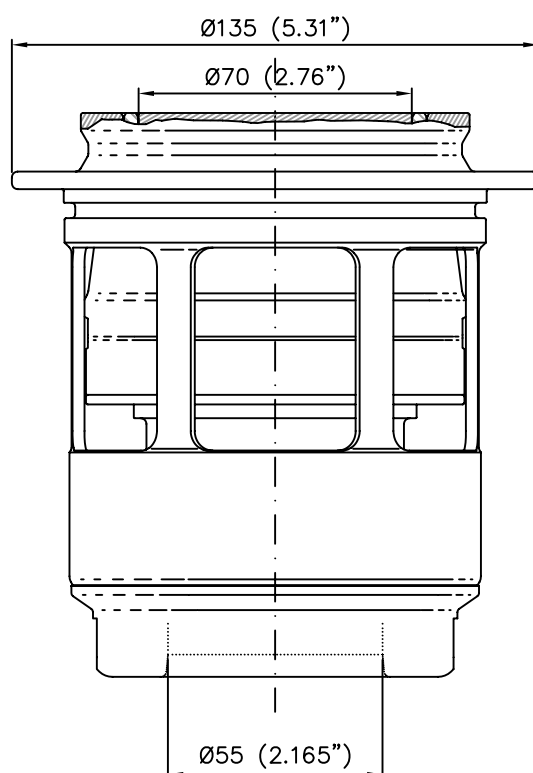

Dessin/Drawing 252-5 version B
Accoupleur femelle / Female coupling

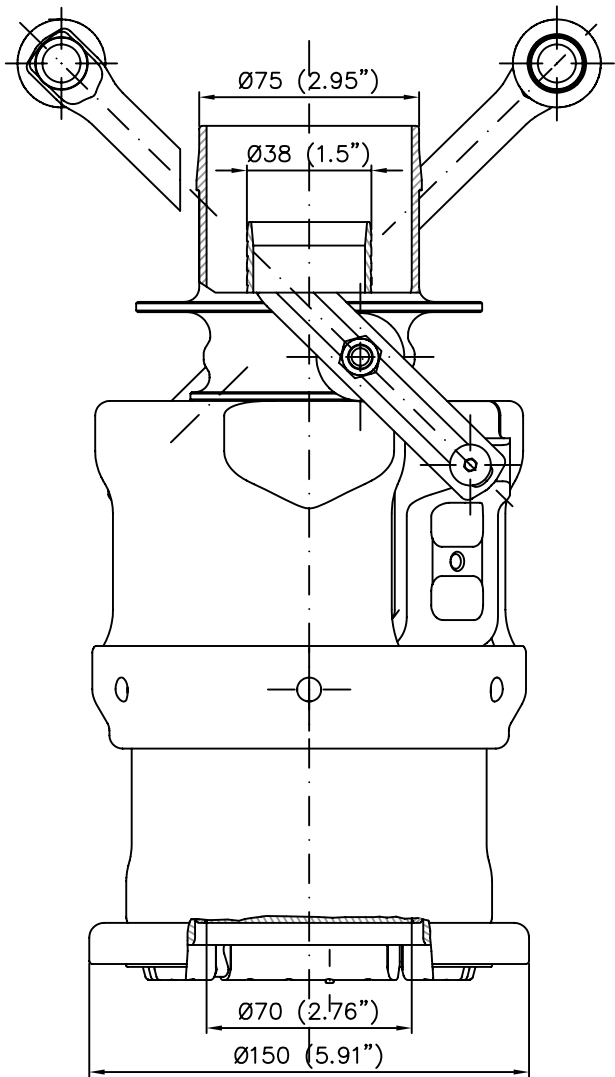

Coaxial

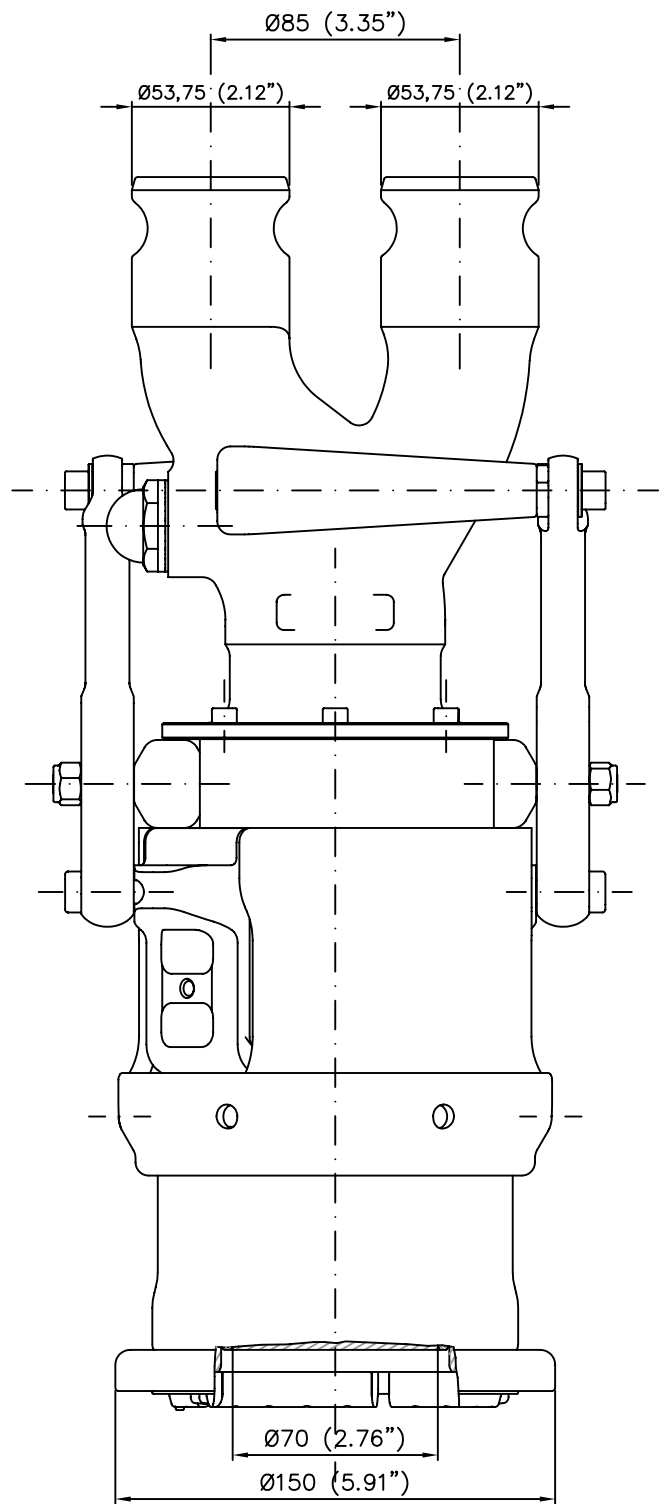

Parallèle / Parallel

Dessin/Drawing 252-5 version B

Accoupleur mâle / Male coupling

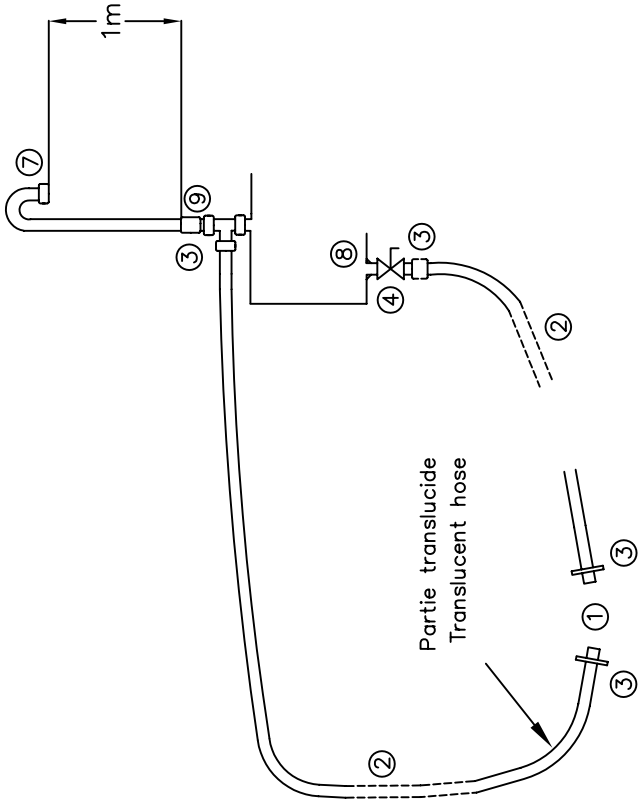
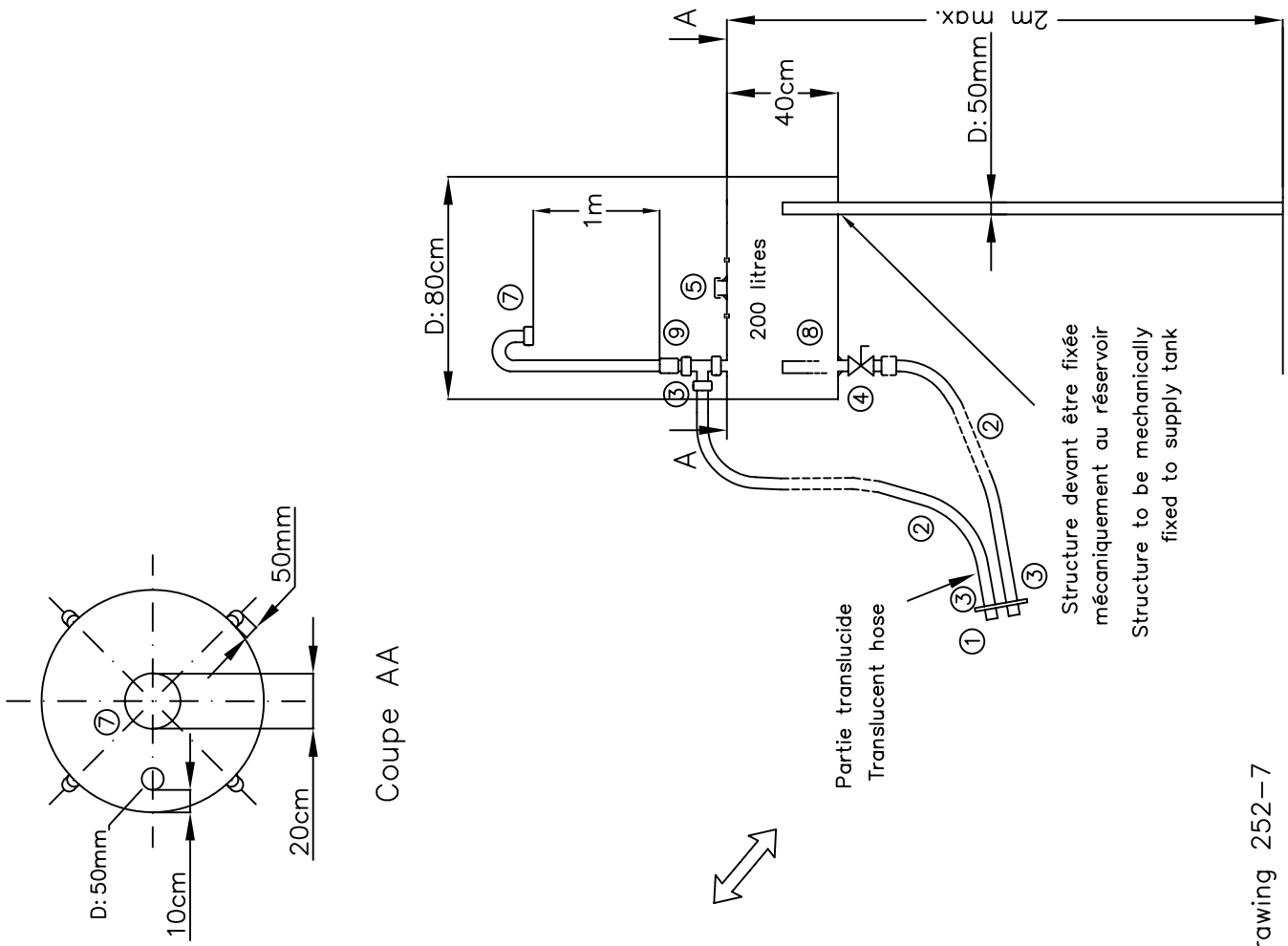

- ① Accoupleurs / Male refuelling valves (dessin / drawing 252-5)
- ② Flexible de diamètre intérieur / Hose internal diameter 38mm
- ③ Raccord rapide, diamètre intérieur / Quick coupling, internal diameter 38mm
- ④ Vanne autobloquante de diamètre intérieur / Self closing valve, internal diameter 38mm
- ⑤ Orifice de remplissage (autobloquant) / Filler (dry break)
- ⑦ Arête flamme / Flame arrester
- ⑧ Restricteur / Flow restrictor (dessin / drawing 258-3)
- ⑨ Valve de séparation / Discriminator valve

Structure devant être fixée
mécaniquement au réservoir
Structure to be mechanically
fixed to supply tank

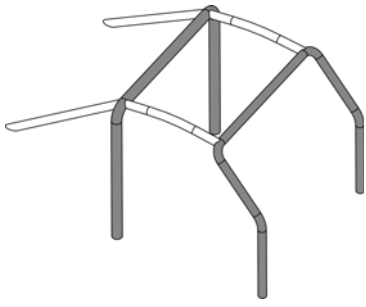

Dessin/Drawing 253-1

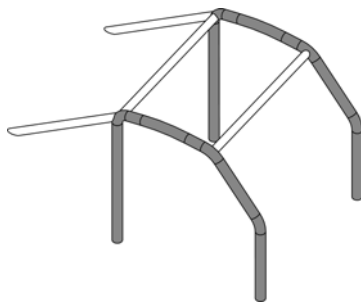

Dessin/Drawing 253-2

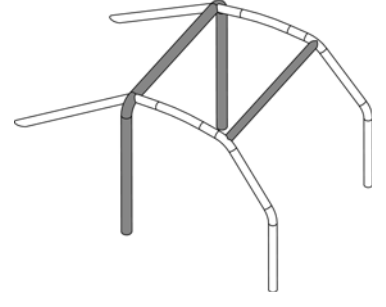

Dessin/Drawing 253-3

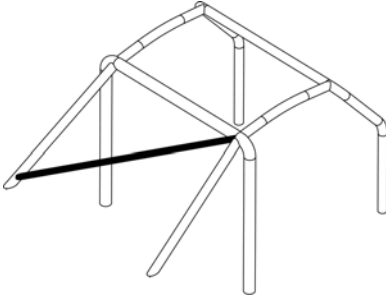

Dessin/Drawing 253-4

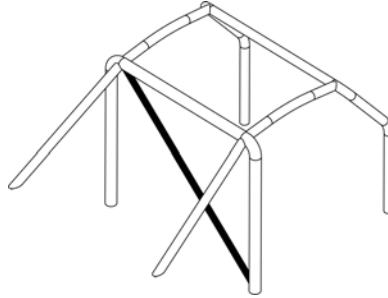

Dessin/Drawing 253-5

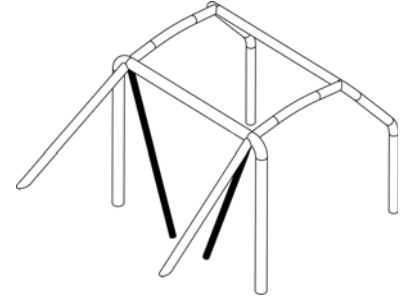

Dessin/Drawing 253-6

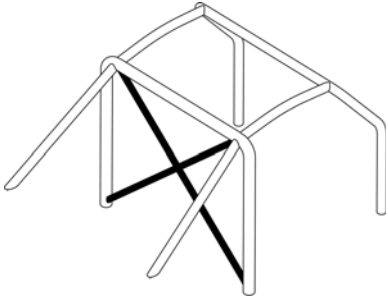

Dessin/Drawing 253-7

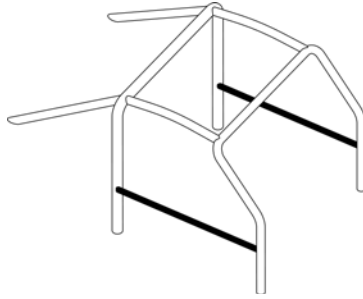

Dessin/Drawing 253-8

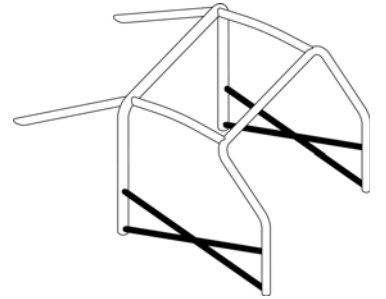

Dessin/Drawing 253-9

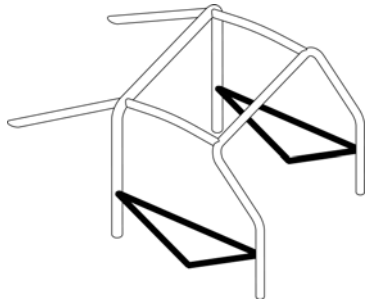

Dessin/Drawing 253-10

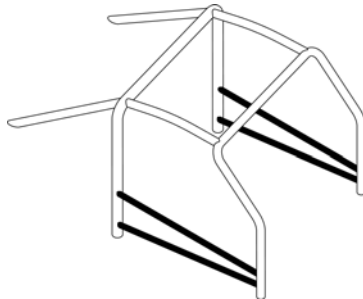

Dessin/Drawing 253-11

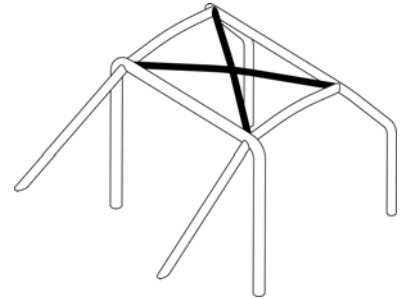

Dessin/Drawing 253-12

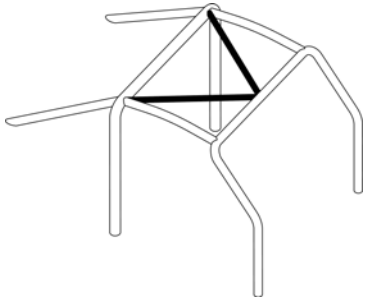

Dessin/Drawing 253-13

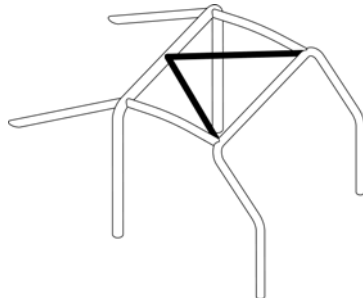

Dessin/Drawing 253-14

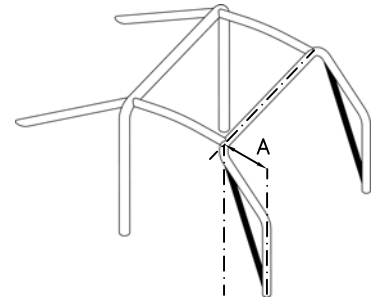

Dessin/Drawing 253-15

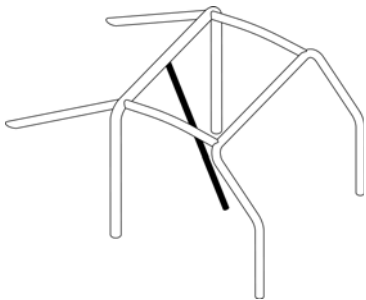

Dessin/Drawing 253-16

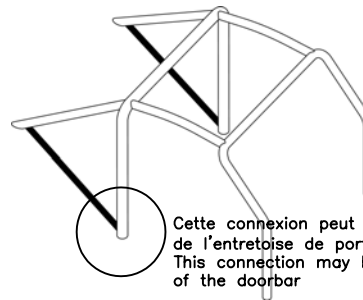

Dessin/Drawing 253-17

Cette connexion peut être au niveau de l'entretoise de portière
This connection may be at the level of the doorbar

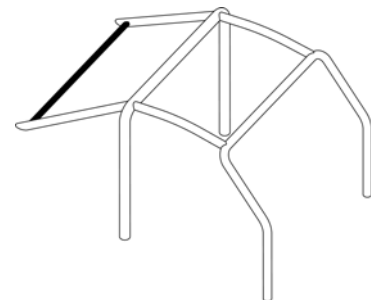

Dessin/Drawing 253-18

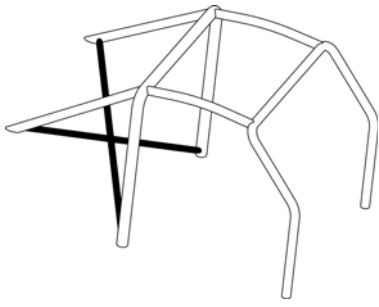

Dessin/Drawing 253-19

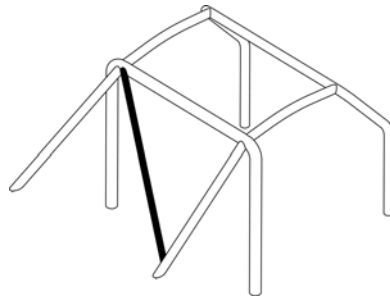

Dessin/Drawing 253-20

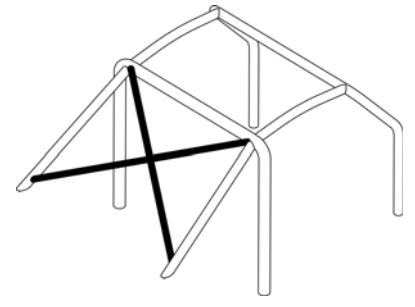

Dessin/Drawing 253-21

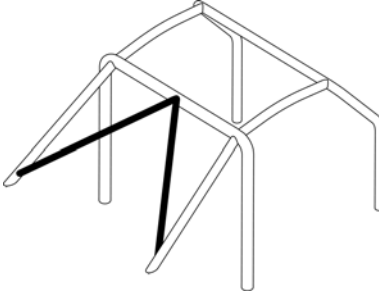

Dessin/Drawing 253-22

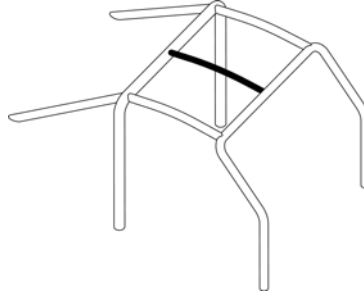

Dessin/Drawing 253-23

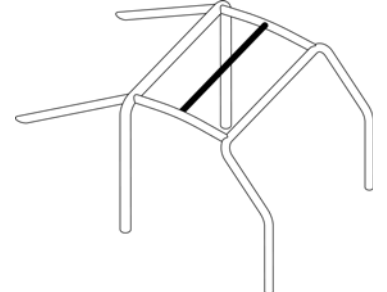

Dessin/Drawing 253-24

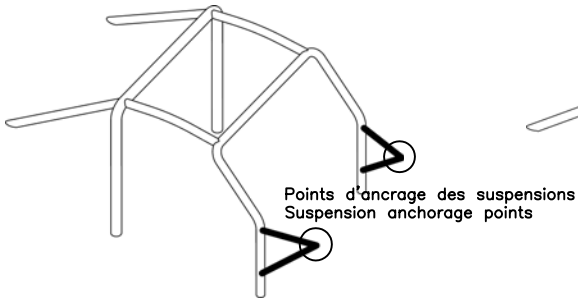

Dessin/Drawing 253-25

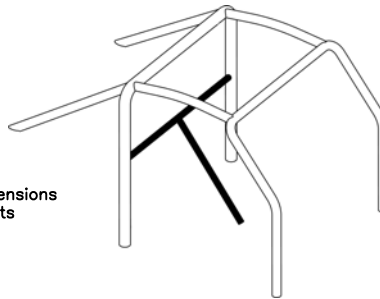

Dessin/Drawing 253-26

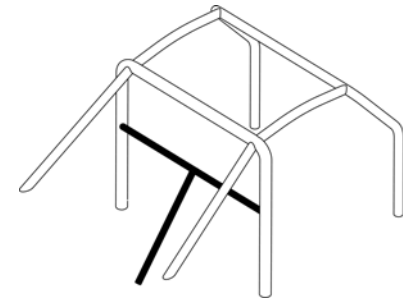

Dessin/Drawing 253-27

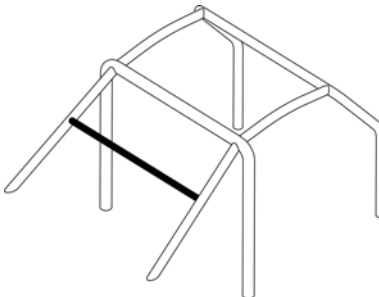

Dessin/Drawing 253-28

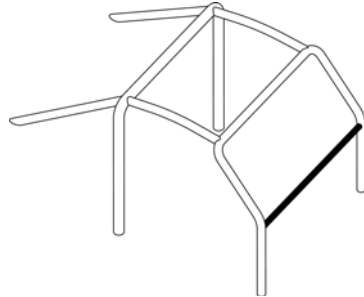

Dessin/Drawing 253-29

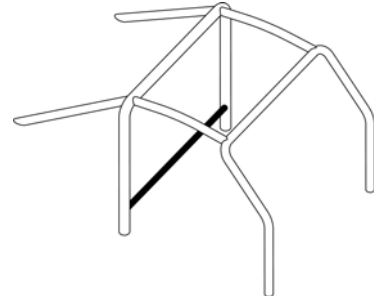

Dessin/Drawing 253-30

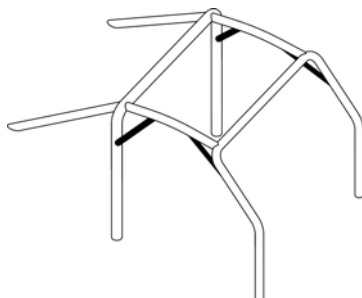

Dessin/Drawing 253-31

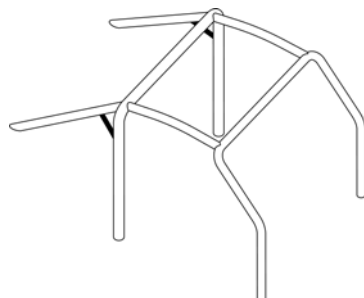

Dessin/Drawing 253-32

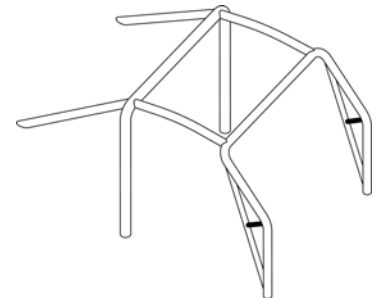

Dessin/Drawing 253-33

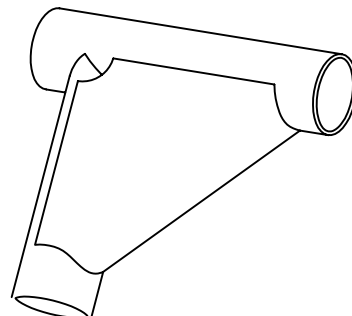

Dessin/Drawing 253-34

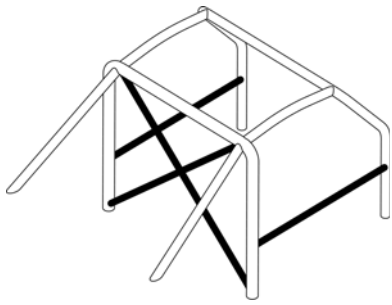

Dessin/Drawing 253-35A

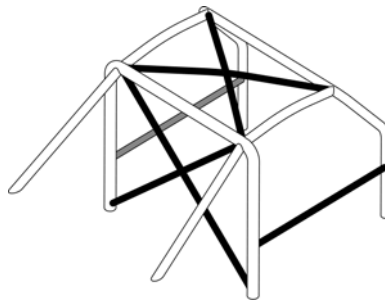

Dessin/Drawing 253-35B

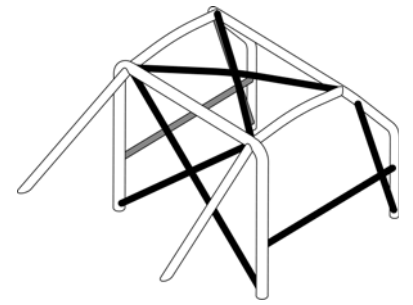

Dessin/Drawing 253-35C

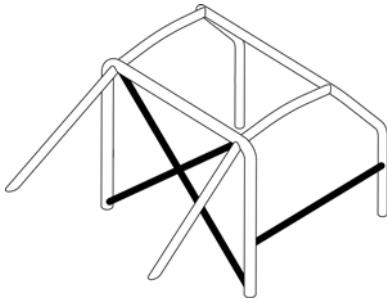

Dessin/Drawing 253-36A

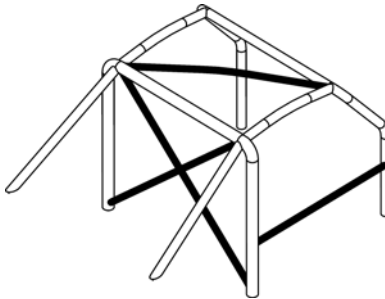

Dessin/Drawing 253-36B

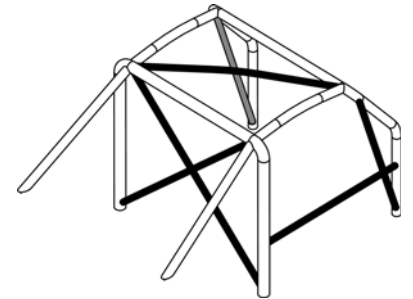

Dessin/Drawing 253-36C

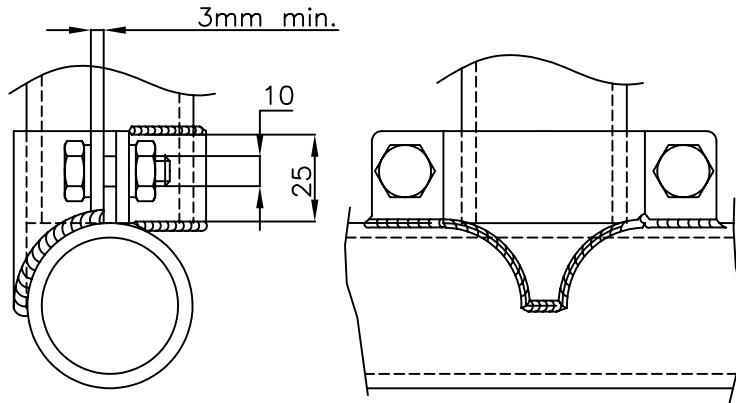

Dessin/Drawing 253-37

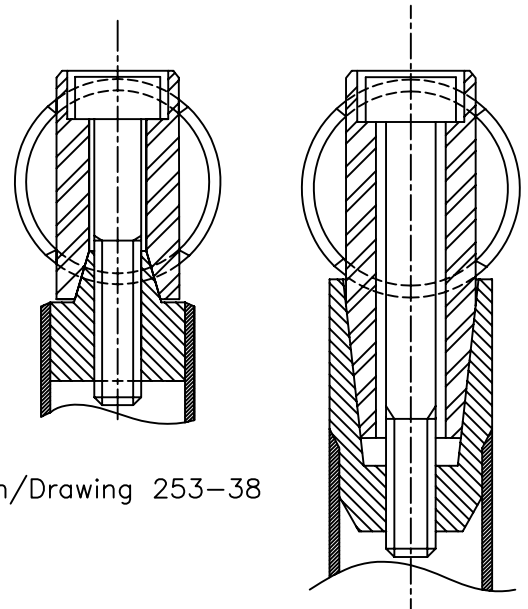

Dessin/Drawing 253-38

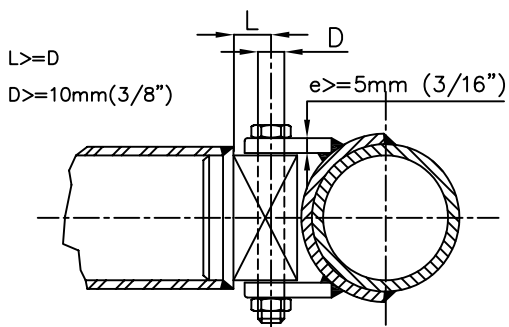

Dessin/Drawing 253-40

Dessin/Drawing 253-39

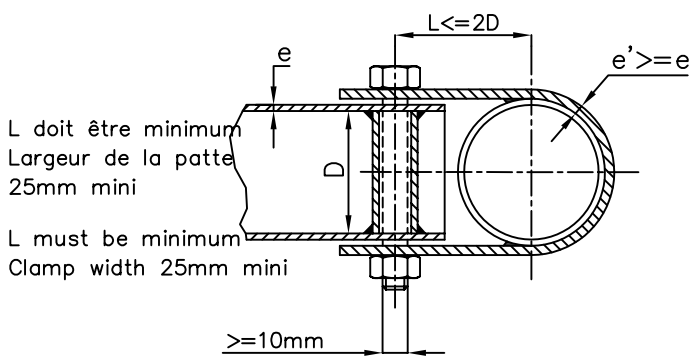

Dessin/Drawing 253-43

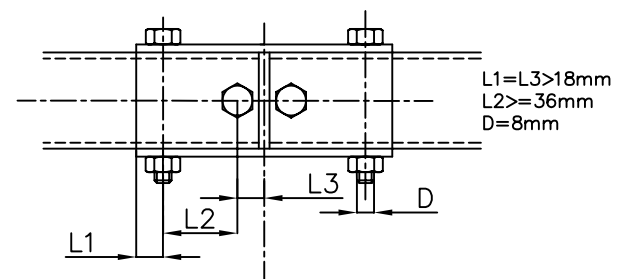

Dessin/Drawing 253-41

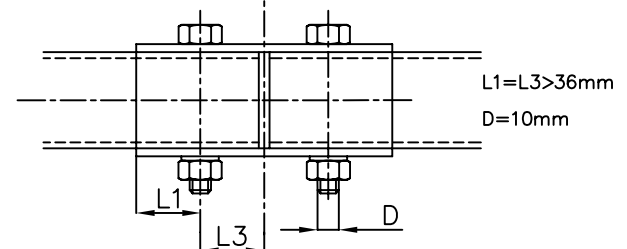

Dessin/Drawing 253-42

soudure
welding

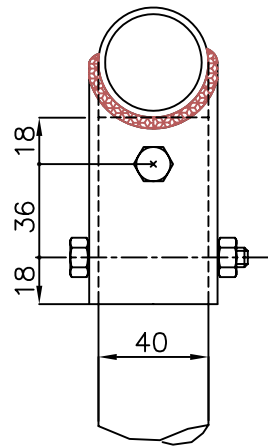
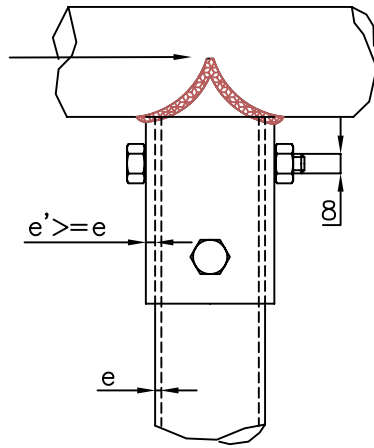

(Dimensions en/in mm)

Dessin/Drawing 253-44

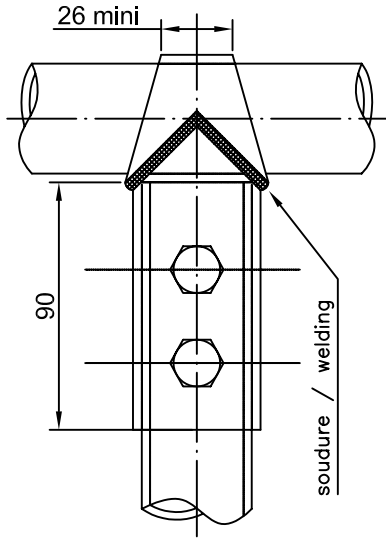
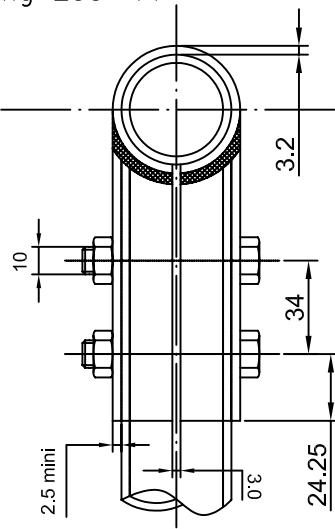
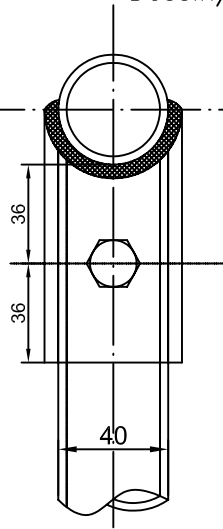
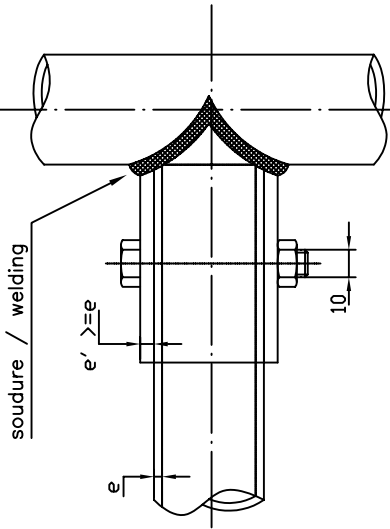

Dessin/Drawing 253-45

Dessin/Drawing 253-46

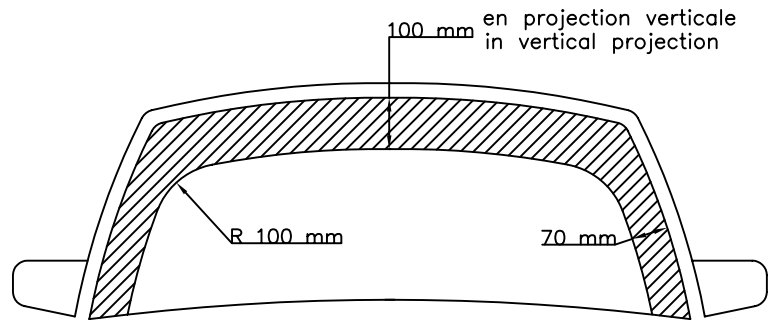
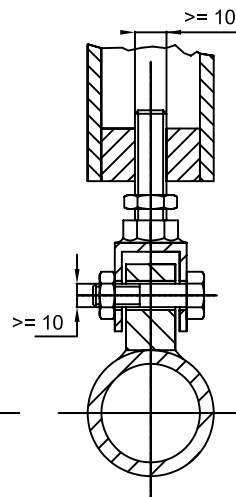
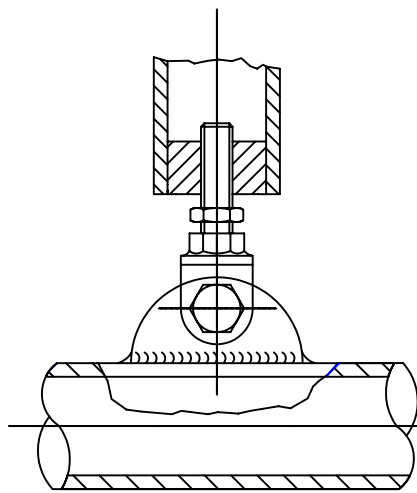

Dessin/Drawing 253-47

Dessin/Drawing 253-48

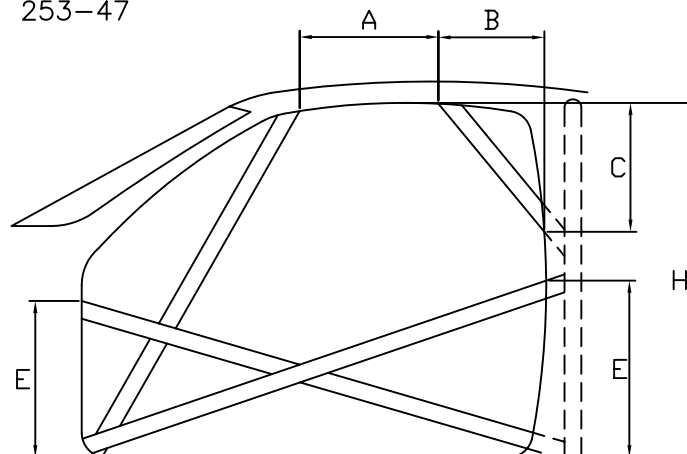

Dessin/Drawing 253-49

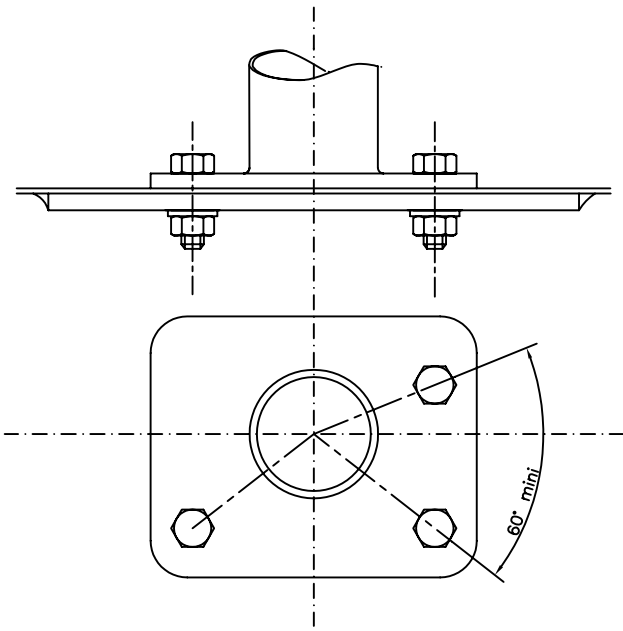

Dessin/Drawing 253-50

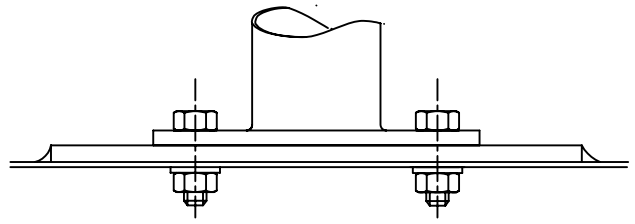

Dessin/Drawing N°253-51

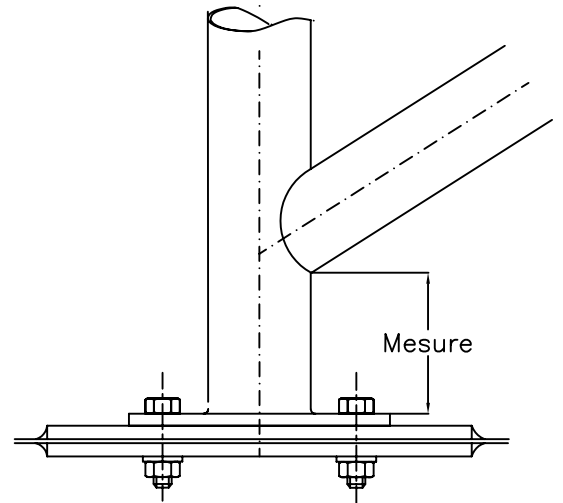

Dessin/Drawing 253-52

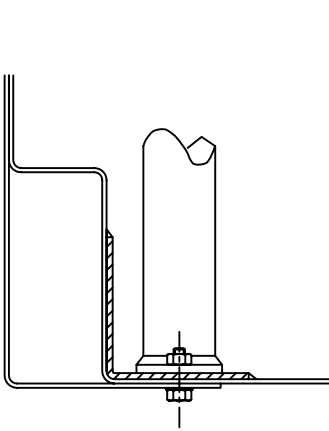

Dessin/Drawing 253-53

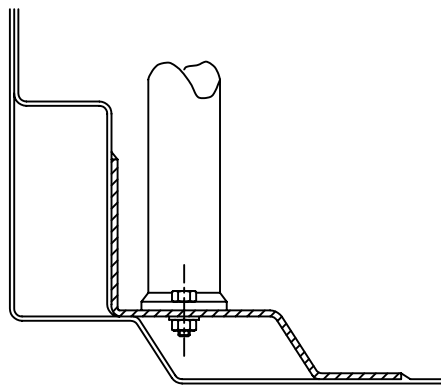

Dessin/Drawing 253-54

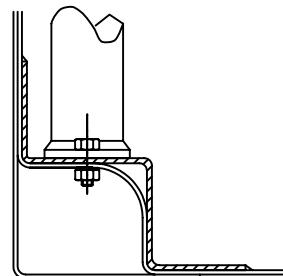

Dessin/Drawing 253-55

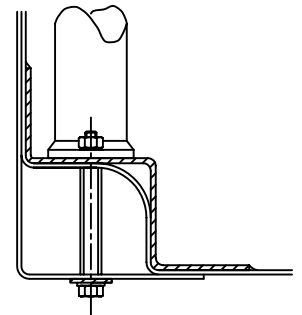

Dessin/Drawing 253-56

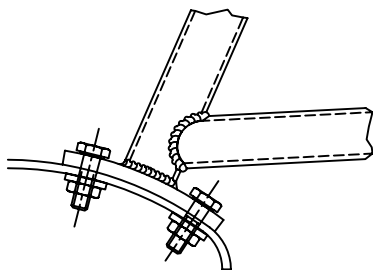

Dessin/Drawing 253-57

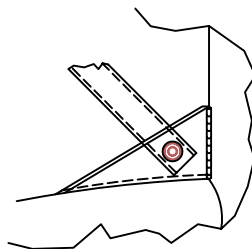

Dessin/Drawing 253-58

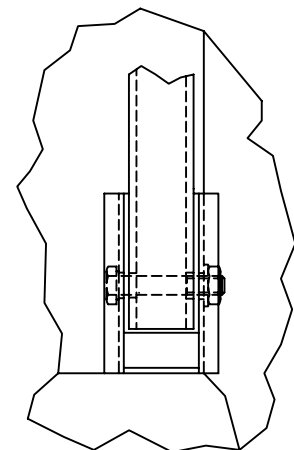

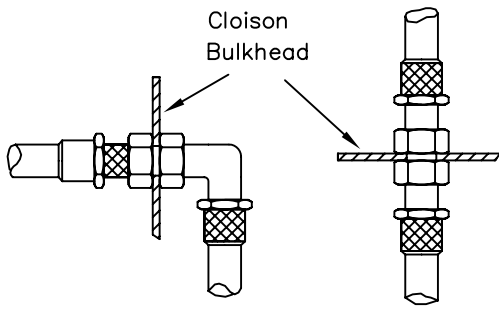

Dessin/Drawing 253-59

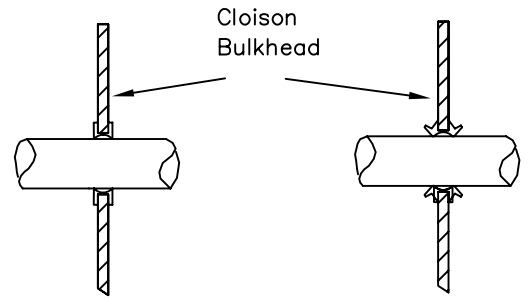

Dessin/Drawing 253-60

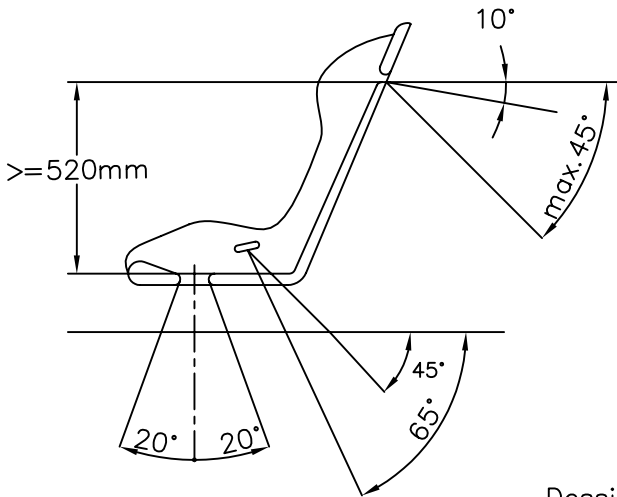

Dessin/Drawing 253-61

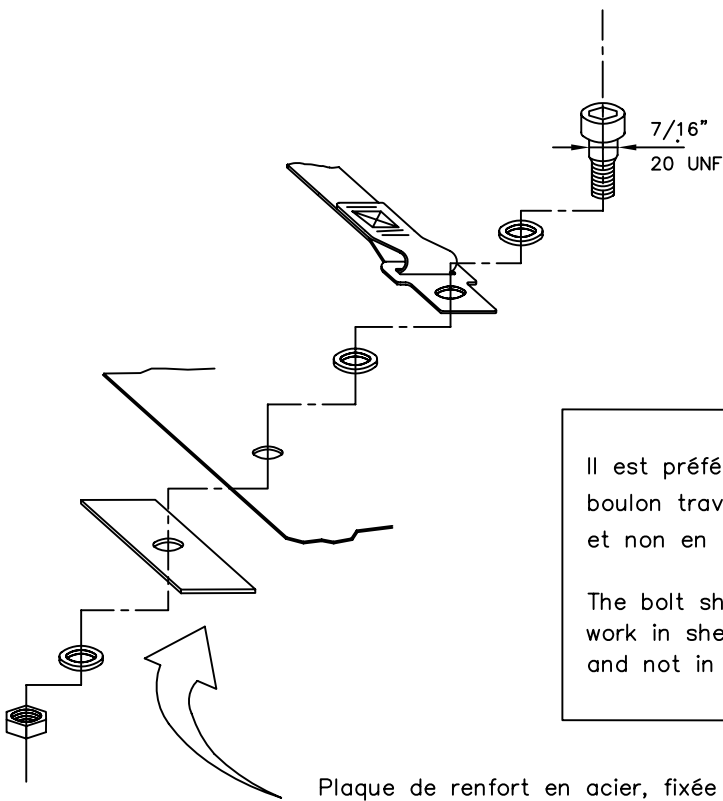
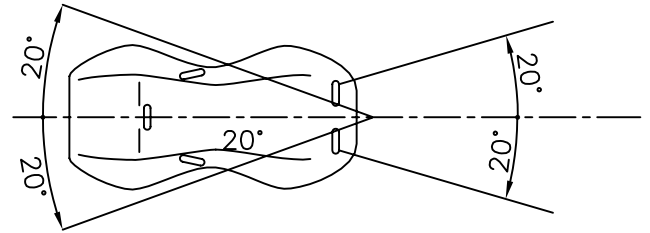

Il est préférable que le
boulon travaille en cisaillement
et non en traction

The bolt should preferably
work in shearing stress
and not in traction

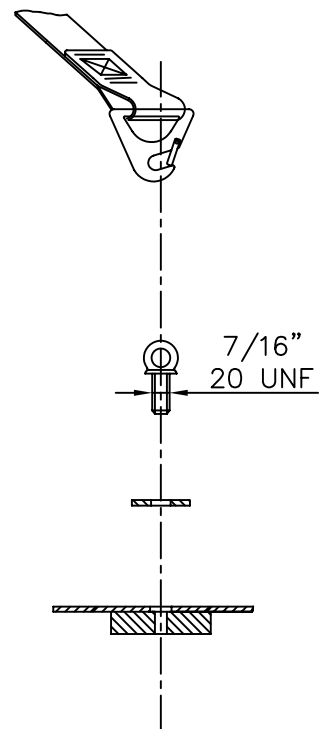

Plaque de renfort en acier, fixée
au châssis de la voiture
Steel reinforcing plate fixed
to the car's chassis

Dessin/Drawing 253-62

plaque fixée au châssis de la voiture et renforcée de l'autre côté par une plaque de renfort

plate fixed to the chassis and strengthened by a reinforced plate on the other side

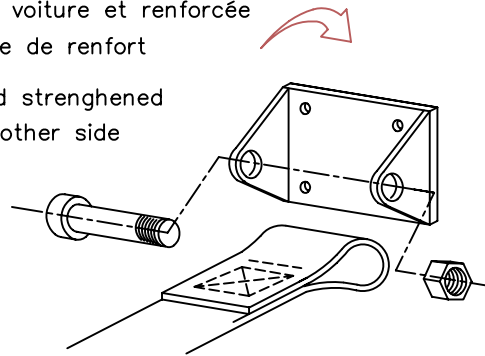

Dessin/Drawing 253-63

plaque de renfort fixée au châssis de la voiture
reinforcing plate fixed to the car's chassis

renfort / reinforcement

coque du siège
seat shell

contre-plaque
conterplate

contre-plaque
conterplate

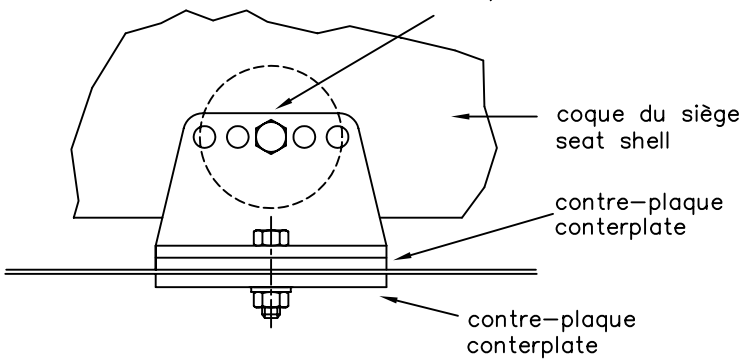

Dessin/Drawing 253-65

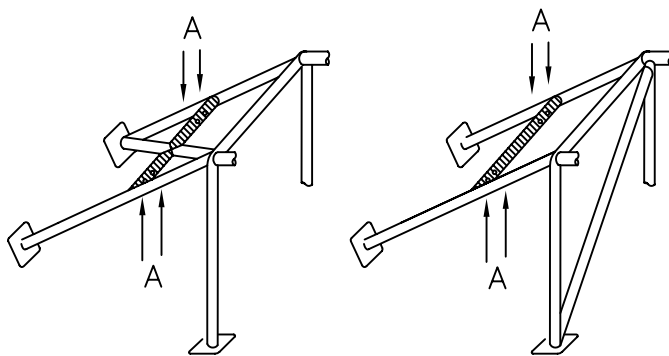

Ⓐ trous de montage pour harnais
mounting holes for harness

Dessin/Drawing 253-66

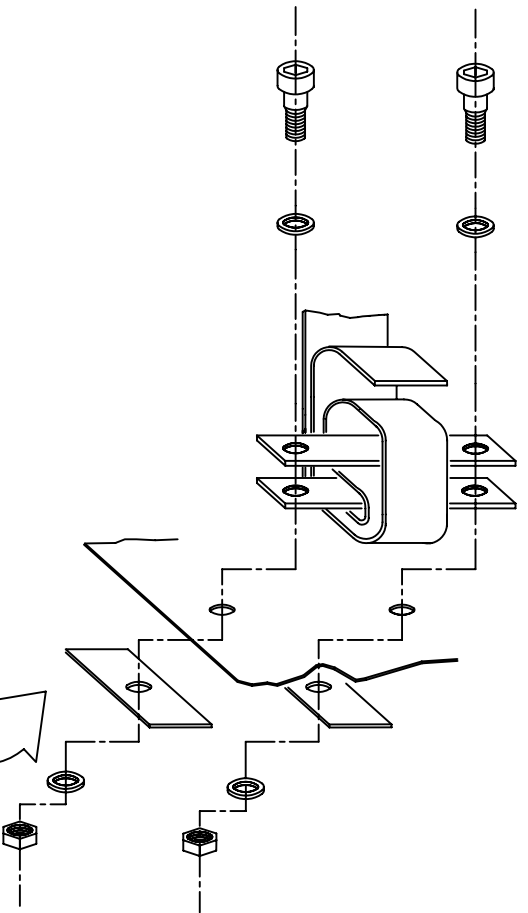

Dessin/Drawing 253-64

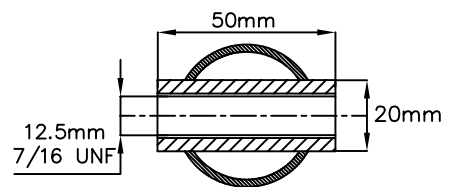

Agrandissement de A
Magnification of A

Dessin/Drawing 253-67

INTERDICTION DE SOUDER LES PLATINES SUR LES CONTRE PLAQUES
END PLATES MUST NOT BE WELDED ON THE COUNTERPLATES

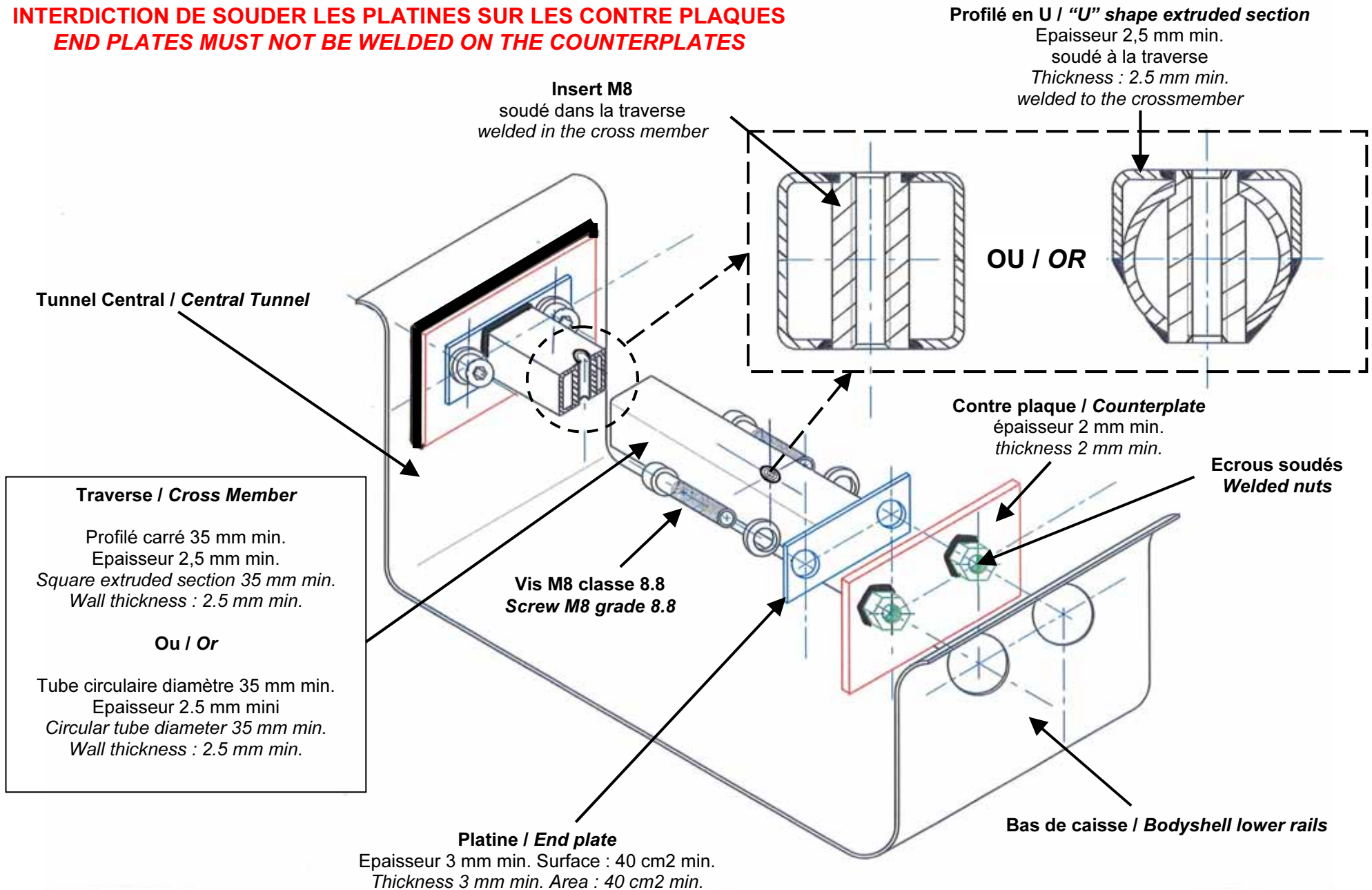

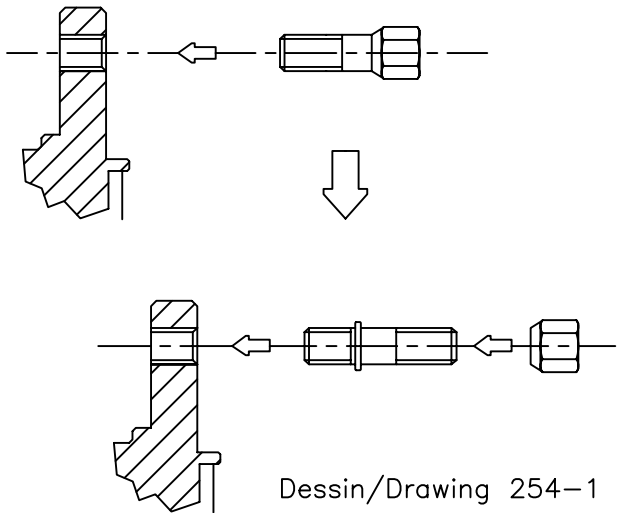

Dessin/Drawing 254-1

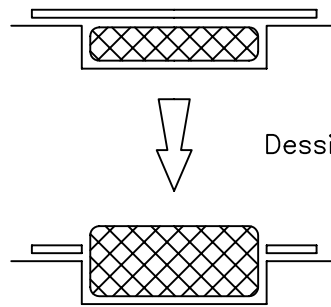

Dessin/Drawing 254-2

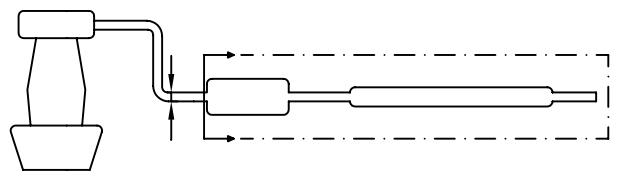

Dessin/Drawing 254-3

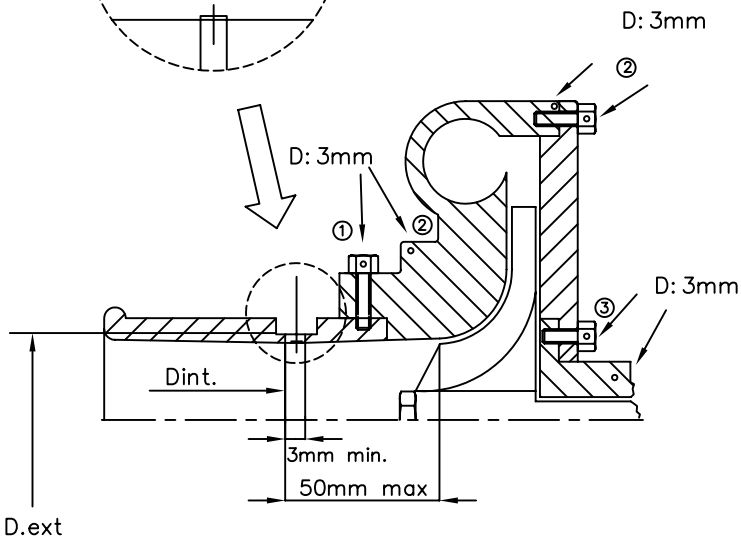
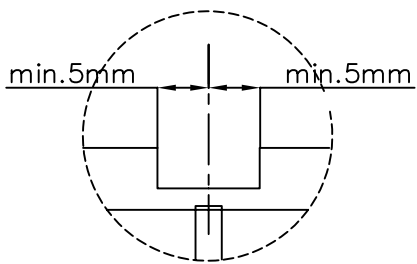

- ① trou pour bride ou bride/carter de compression
hole for restrictor/compressor housing
- ② trou pour carter de compression ou carter/flasque
hole for compressor housing or housing/flange
- ③ trou pour carter central ou carter/flasque
hole for central housing or housing/flange

AUTRES POSSIBILITES :

OTHER POSSIBILITES :

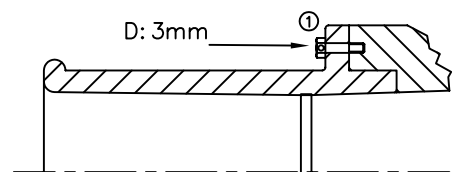
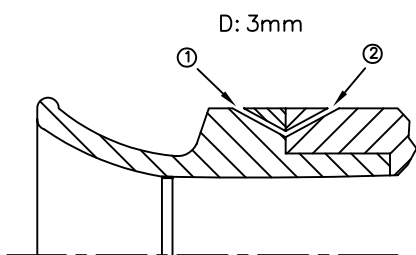

Dessin/Drawing 254-4

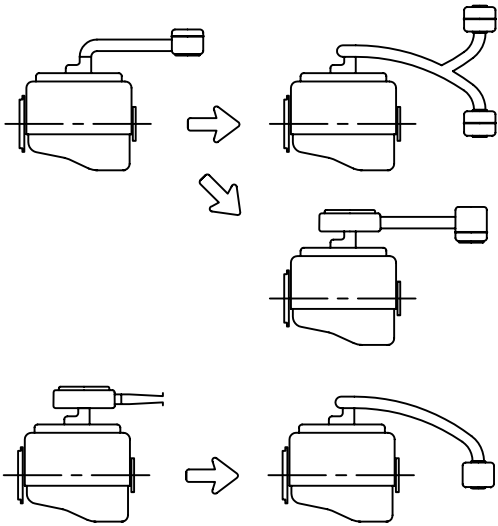

Dessin/Drawing 255-1

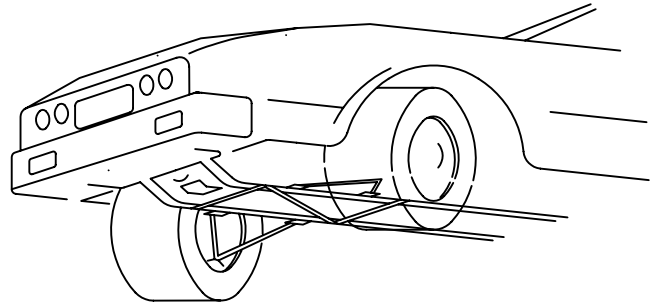

Dessin/Drawing 255-2

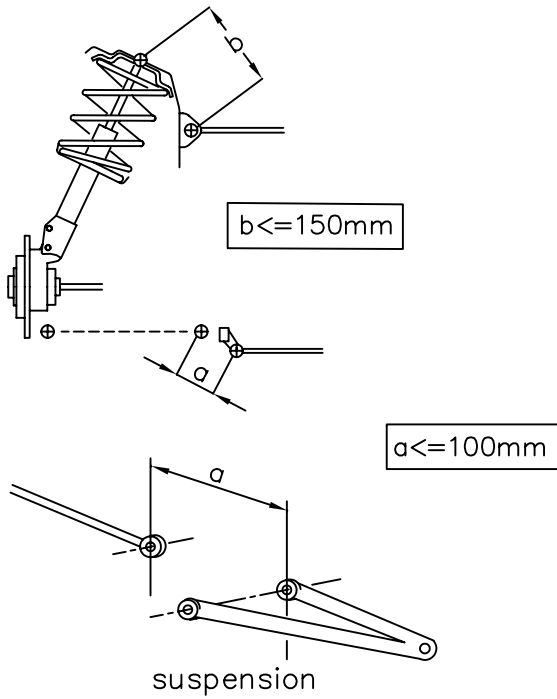

Dessin/Drawing 255-4

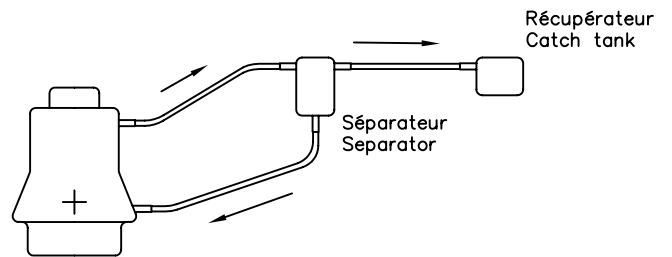

Dessin/Drawing 255-3

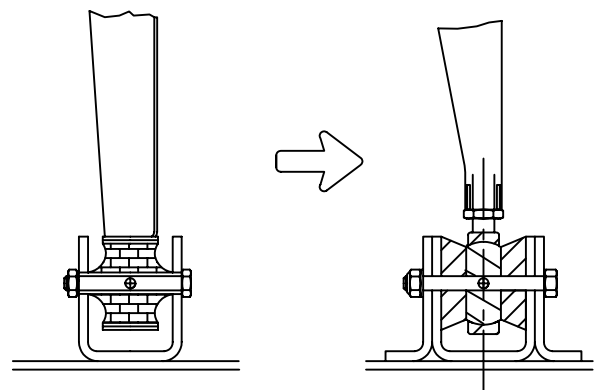

Dessin/Drawing 255-5

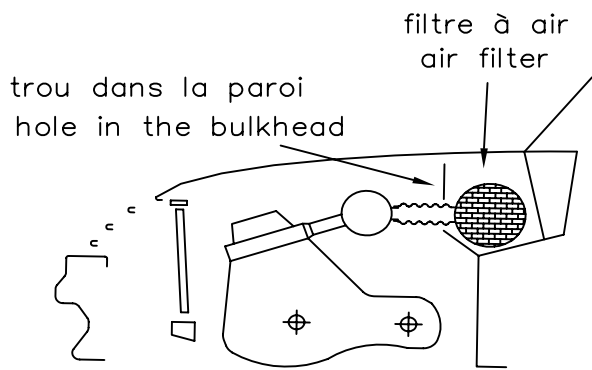

Dessin/Drawing 255-6

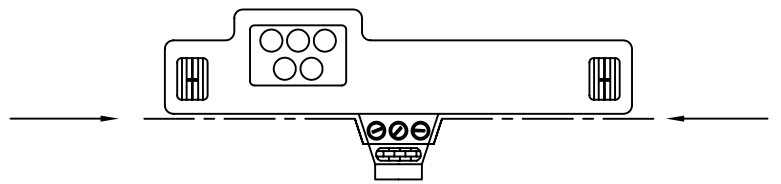

Dessin/Drawing 255-7

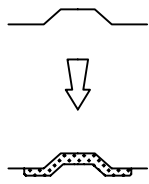

Dessin/Drawing 255-8

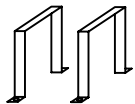
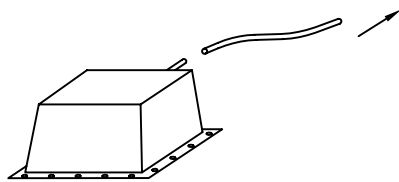

Dessin/Drawing 255-10

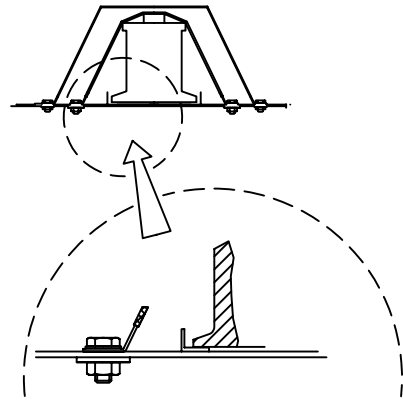
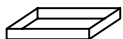
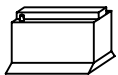

Dessin/Drawing 255-11

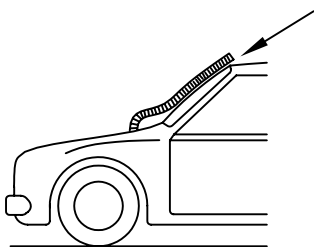

Dessin/Drawing 255-13

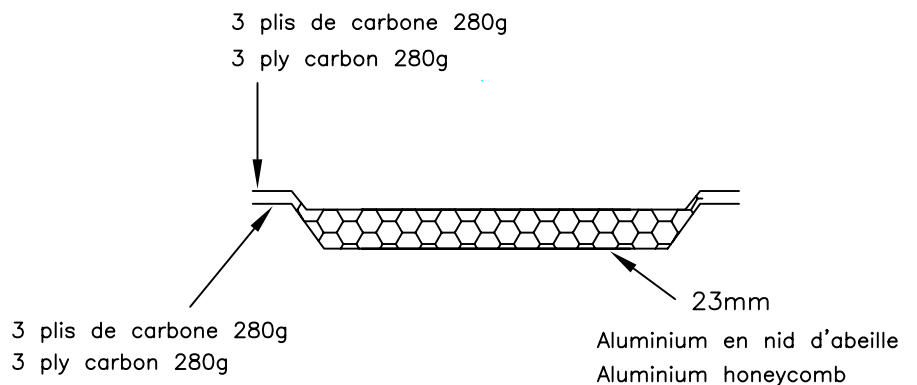

Carbone 4/4 double 280gms E620

Carbon 4/4 twin 280gms E620

Aluminium en nid d'abeille 23mm 1/8" cel4.5 ou 6.35

Aluminium honeycomb 23mm 1/8" cel4.5 or 6.35

Dessin/Drawing 255-14

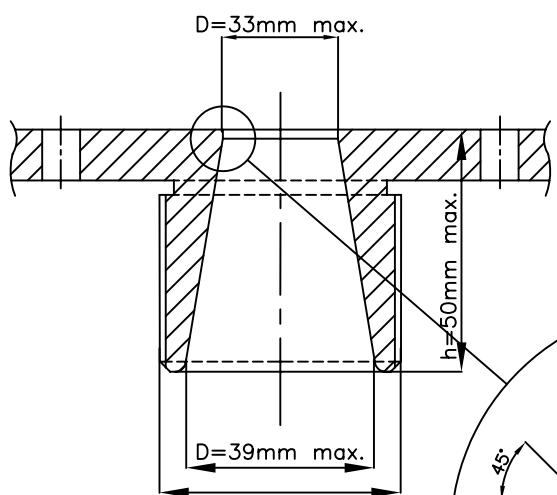
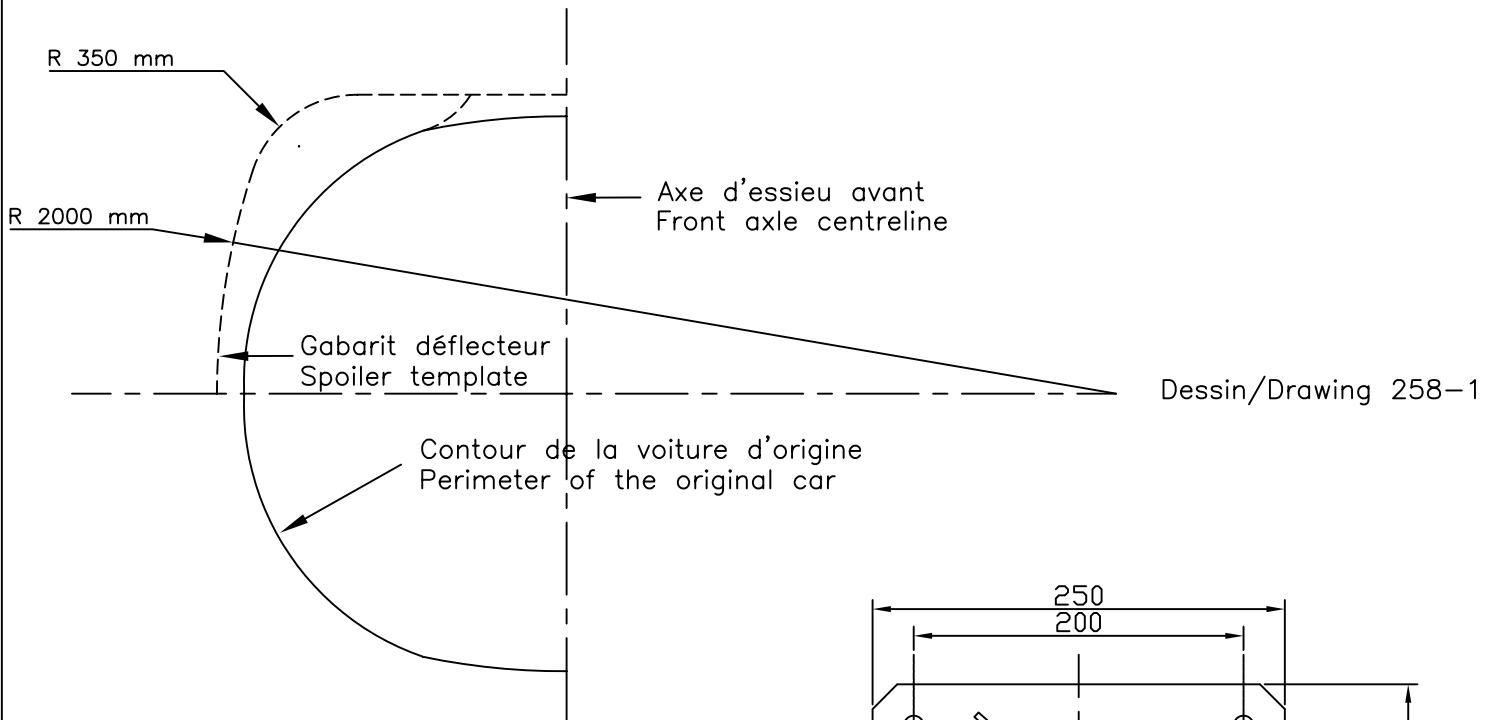

Pour vanne
1/4 de tour
For quarter
turn valve

Dessin /Drawing 258-3

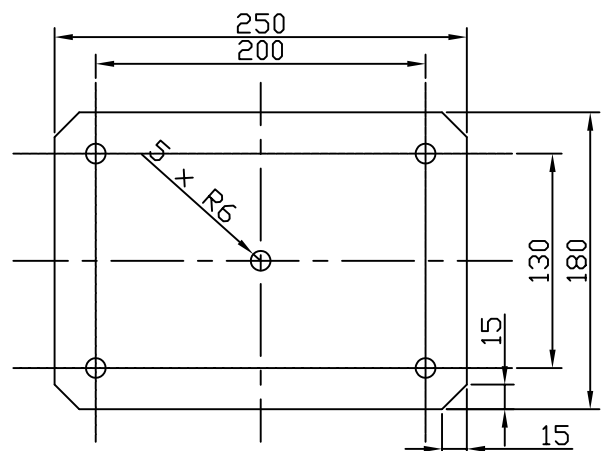

Dessin/Drawing 258-2

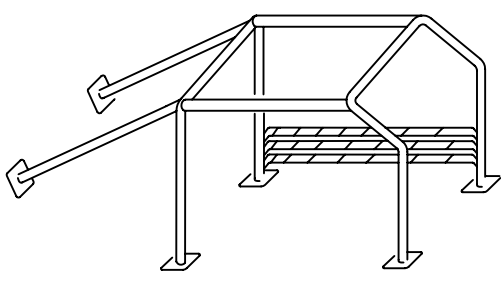
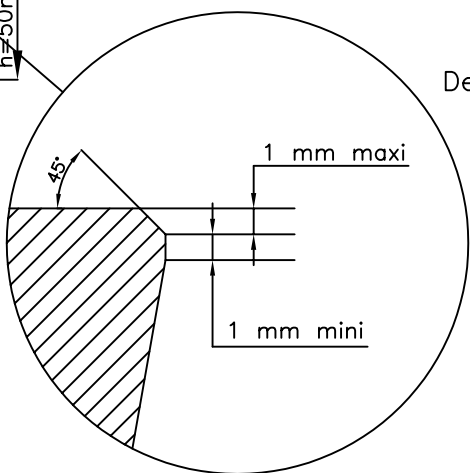

Dessin/Drawing 258-4

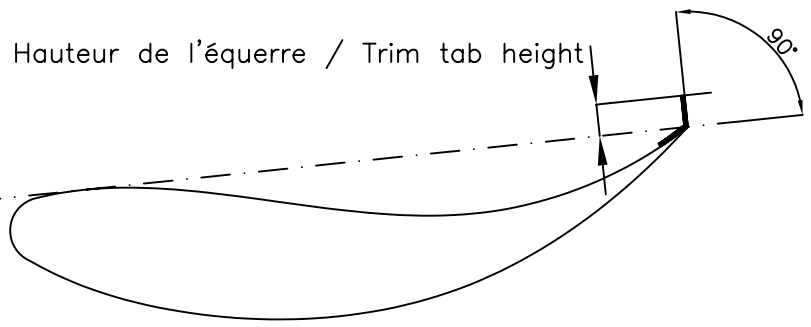

Dessin/Drawing 258-5

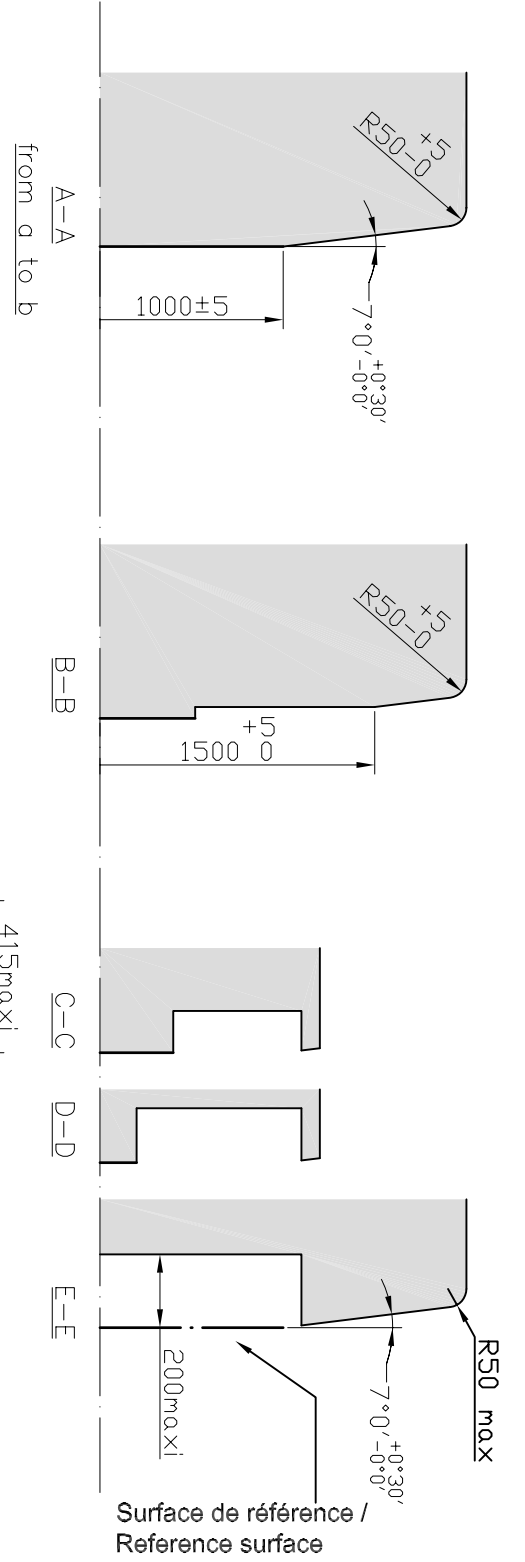
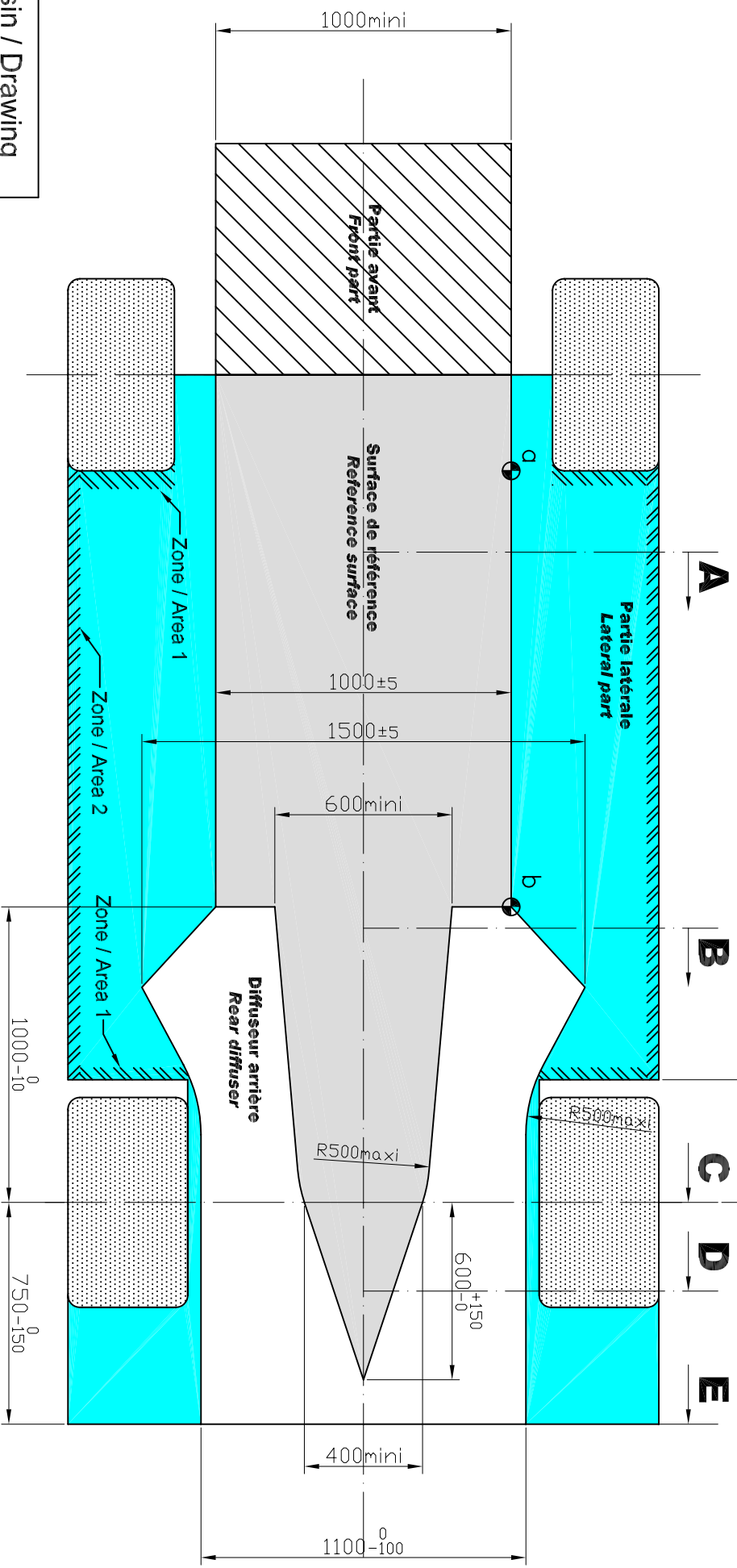

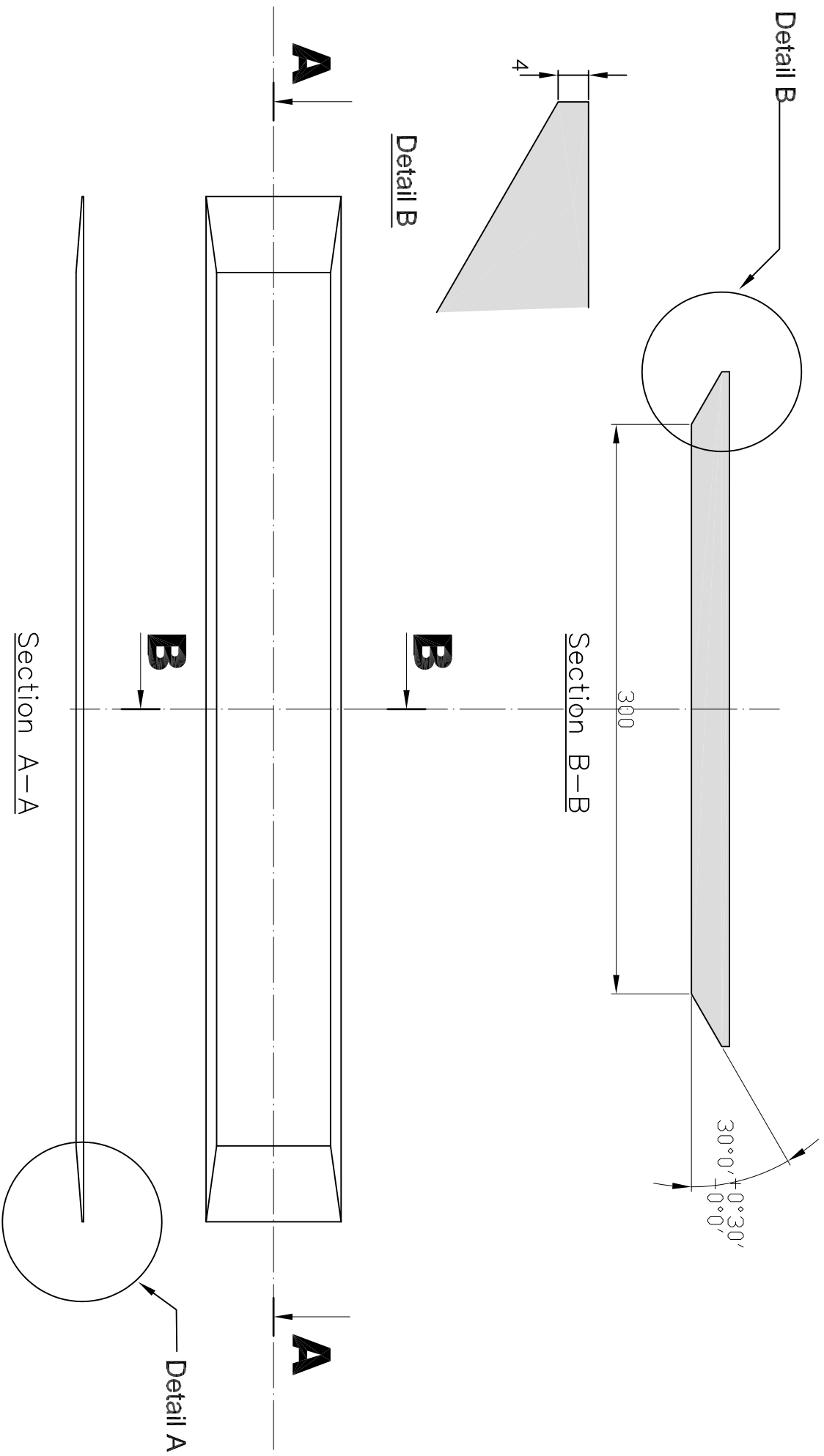

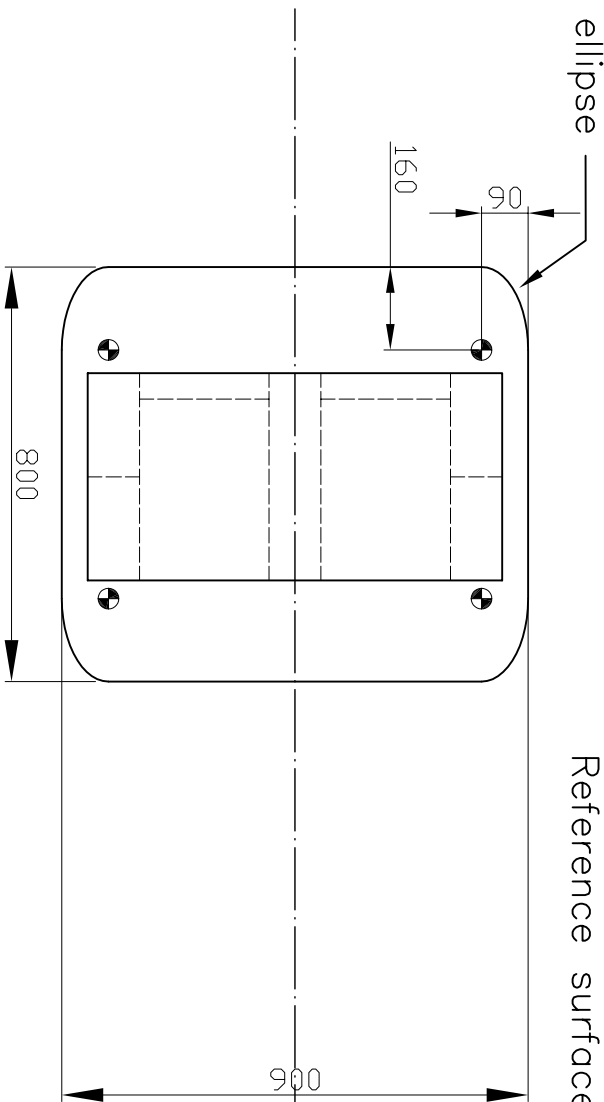
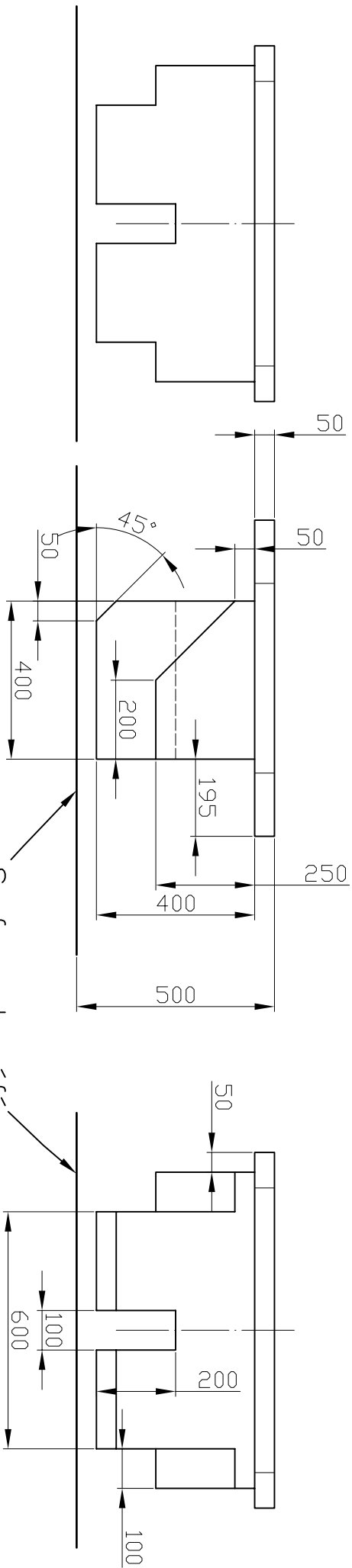

ellipse

Surface de référence

Reference surface

Axe longitudinal voiture

Car's longitudinal centerline

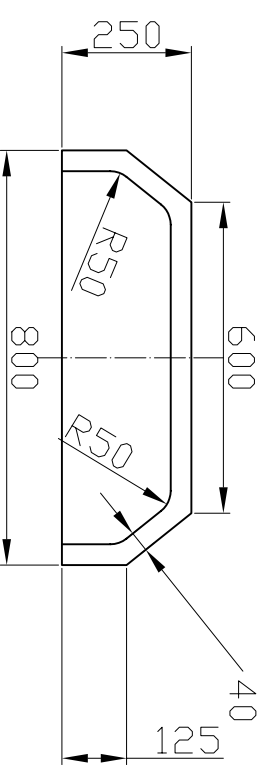
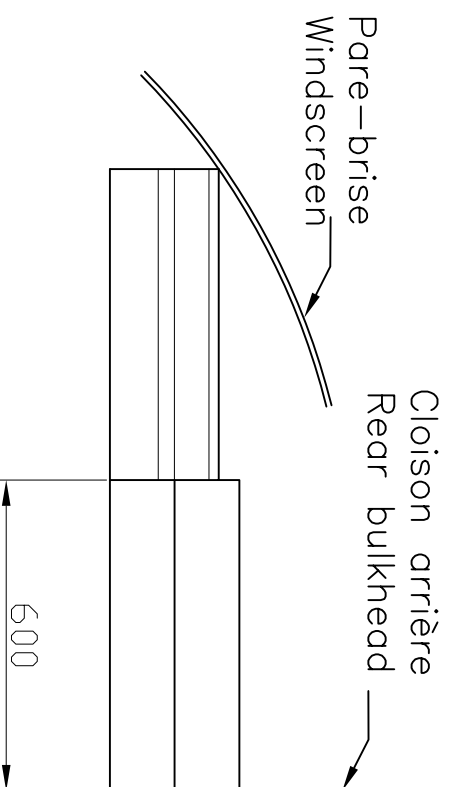

Dessin / Drawing n°258A-4
 Gabarit / Template n°2

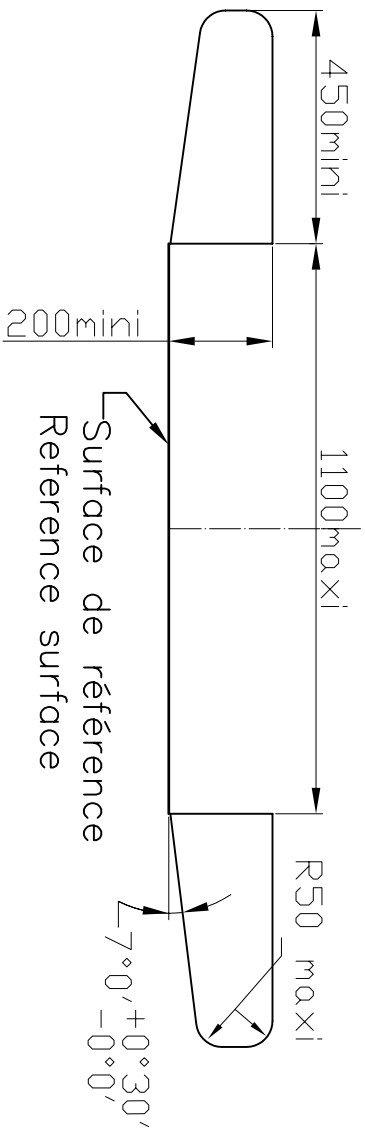

Dessin / Drawing n°258A-5

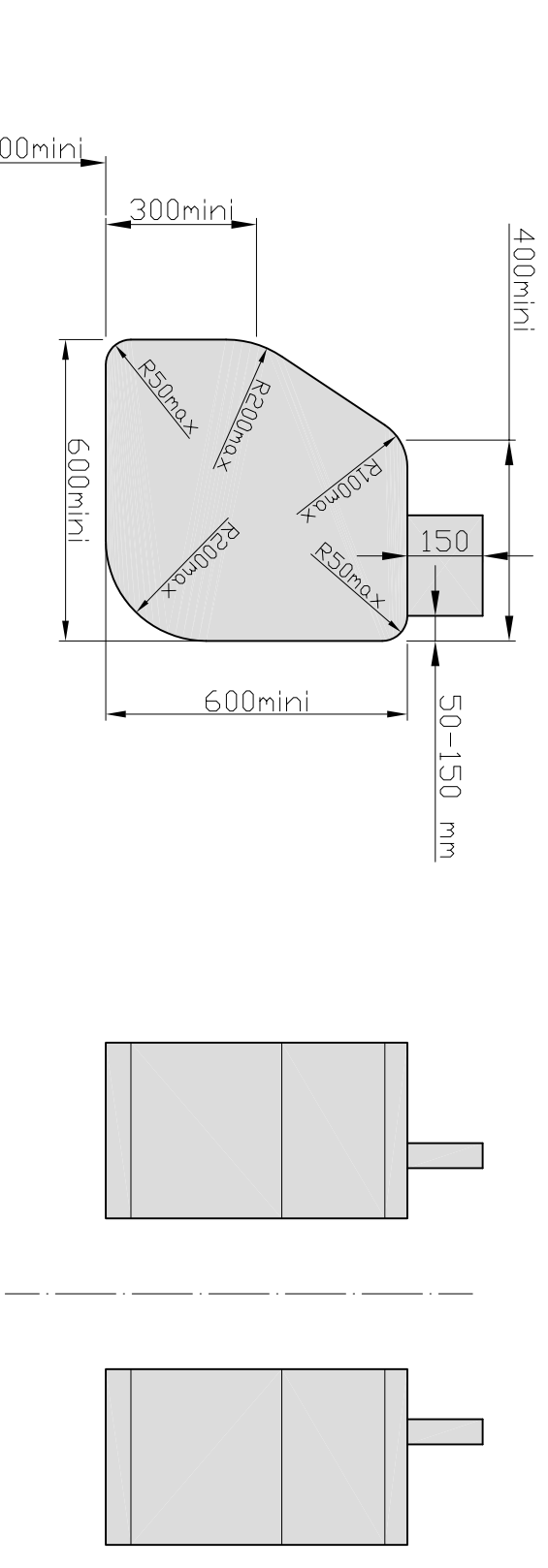

Surface de référence
Reference surface

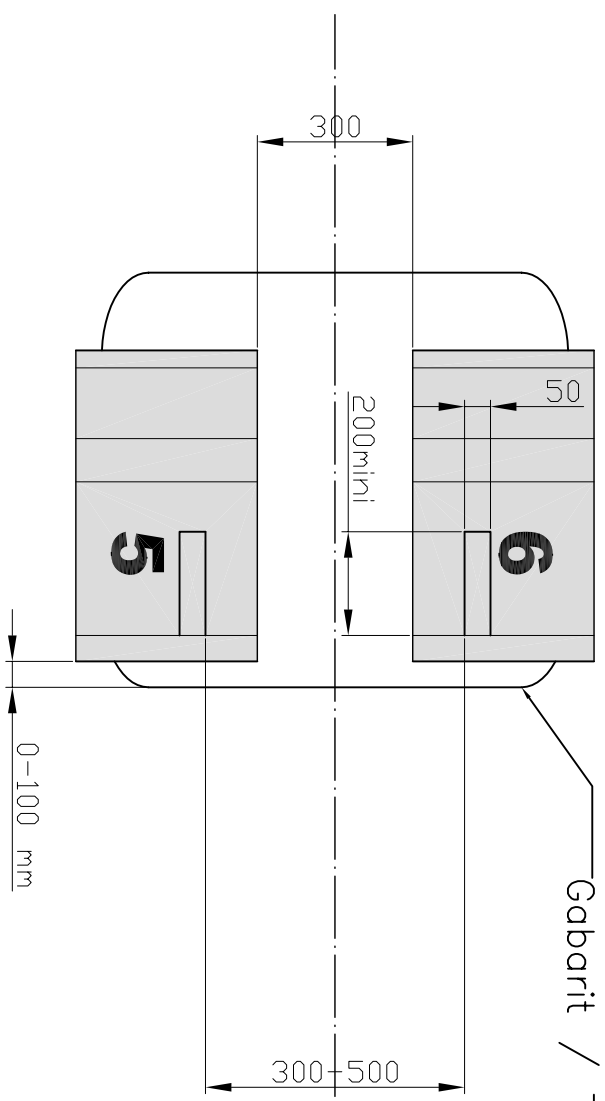

Gabarit / Template n°1

Axe longitudinal voiture
Car's longitudinal centreline

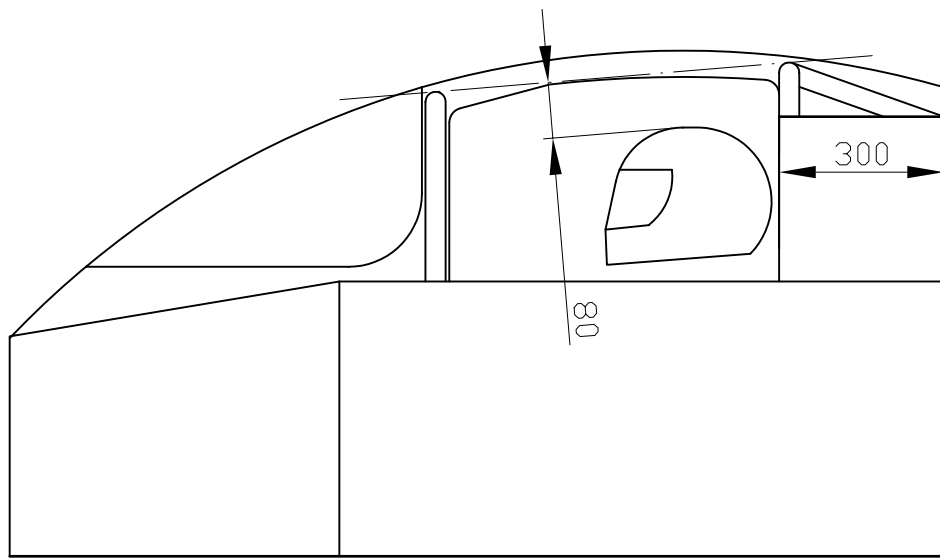
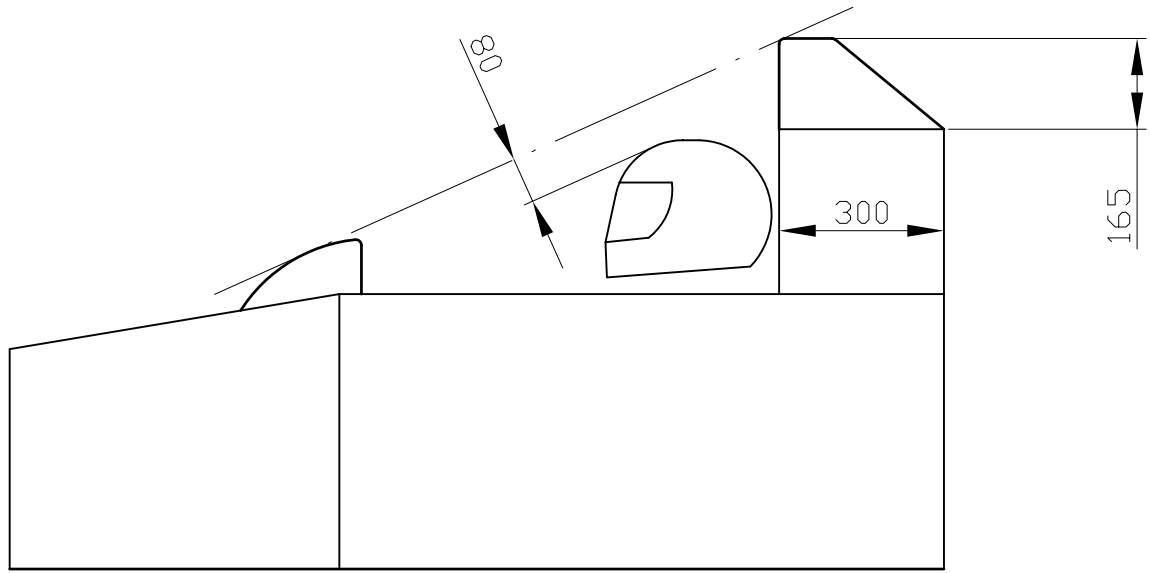

Dessin / Drawing
258A-9

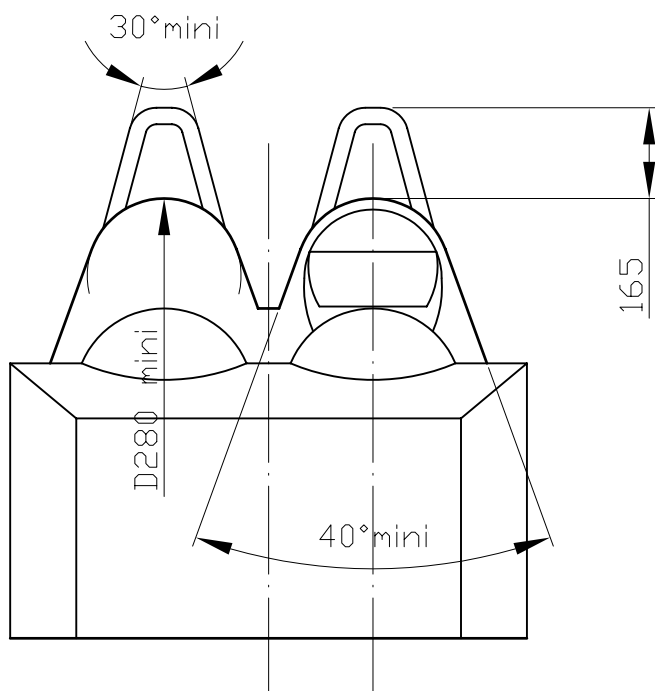

Dessin / Drawing
258A-10

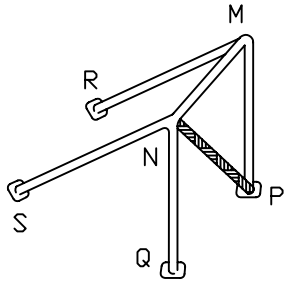

Dessin/Drawing 259-1

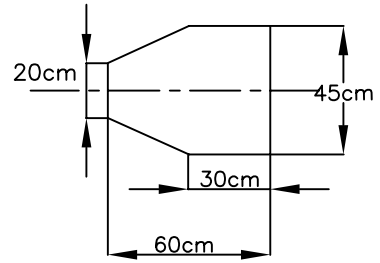

Dessin/Drawing 259-2

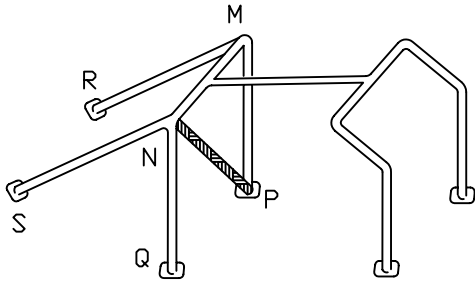

Dessin/Drawing 259-3

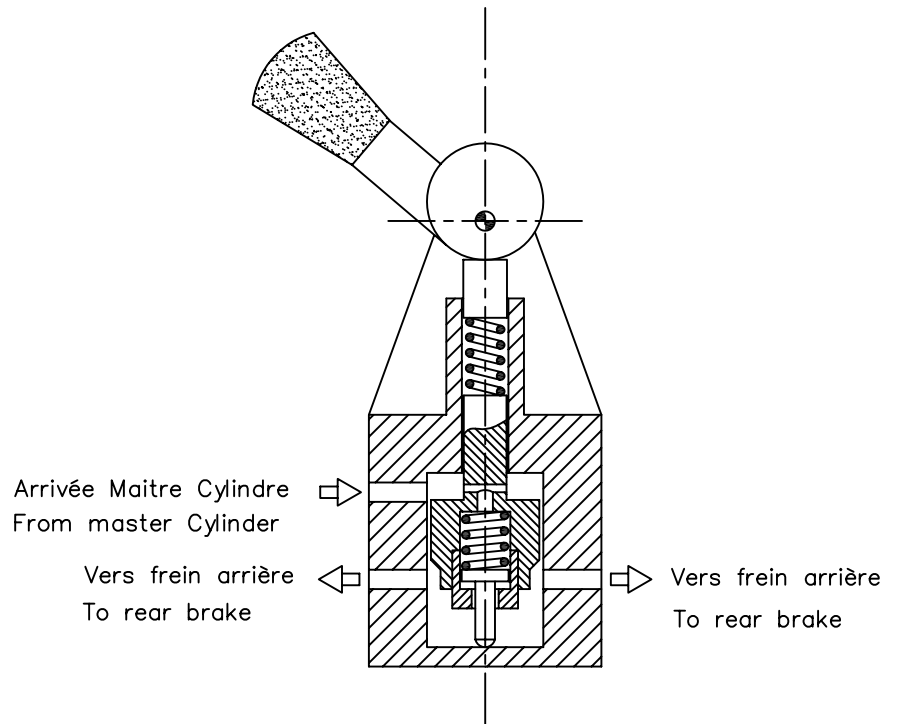

Dessin/Drawing N°263-9

Dimensions en/in millimètres.

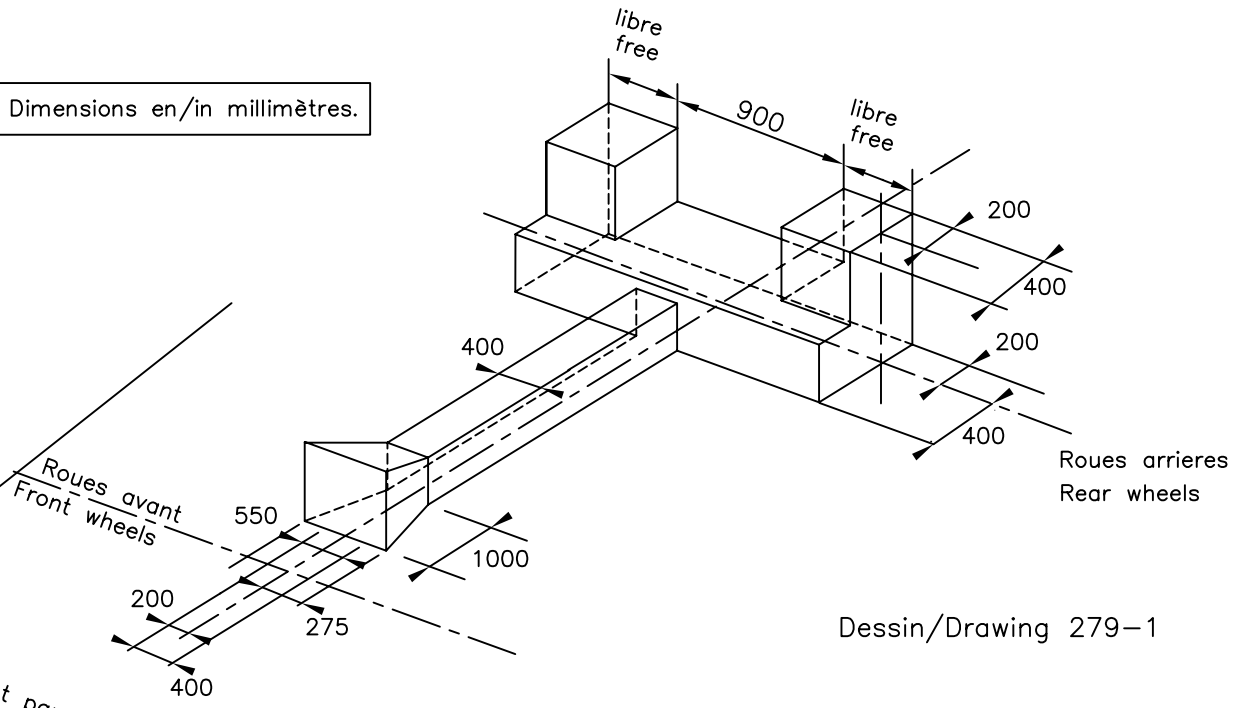

Dessin/Drawing 279-1

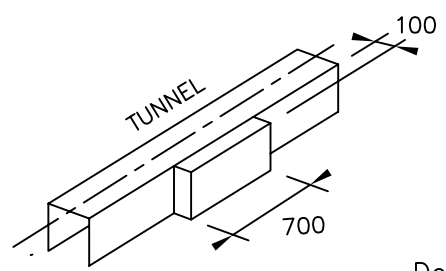
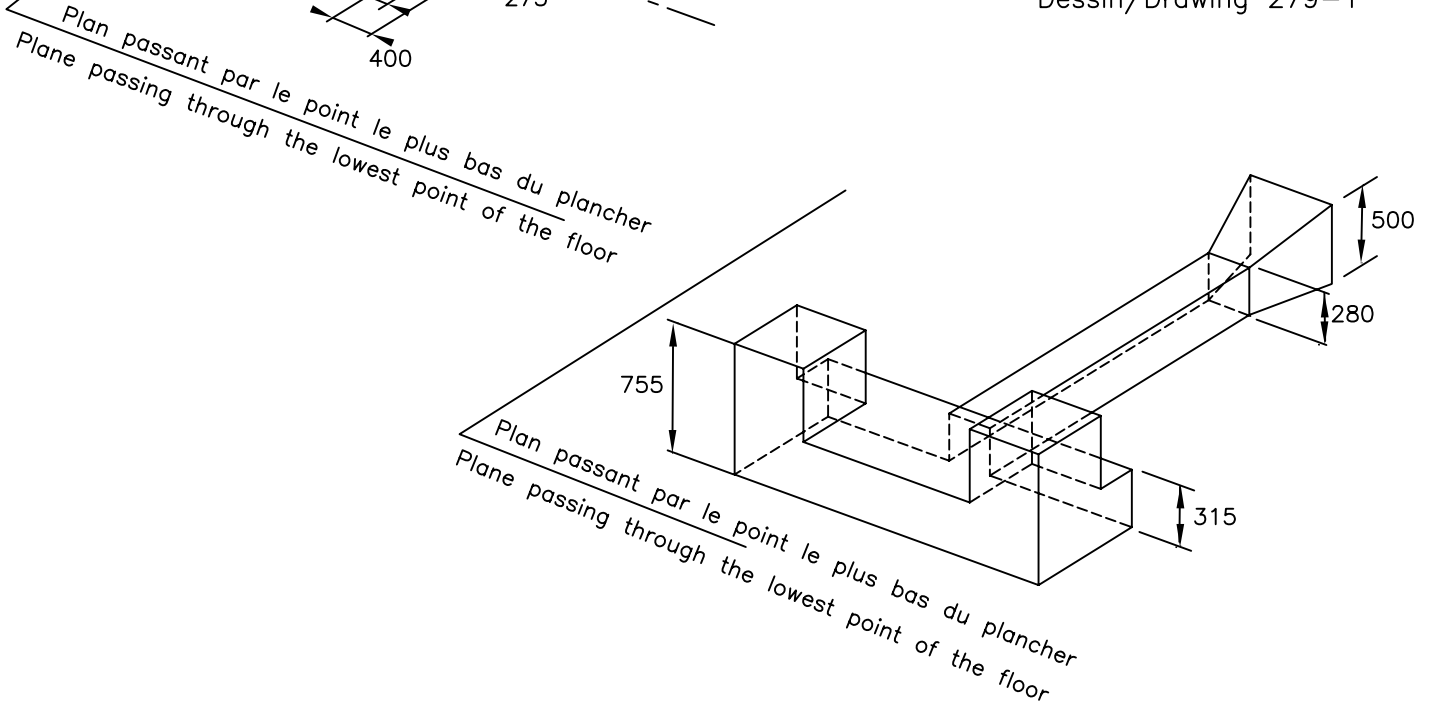

Dessin/Drawing 279-2

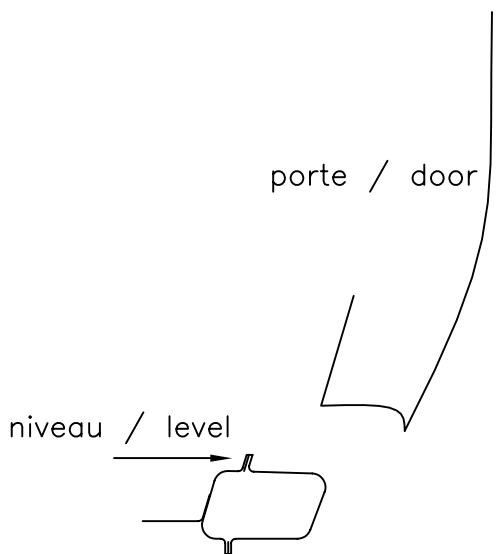

Dessin/Drawing 279-3

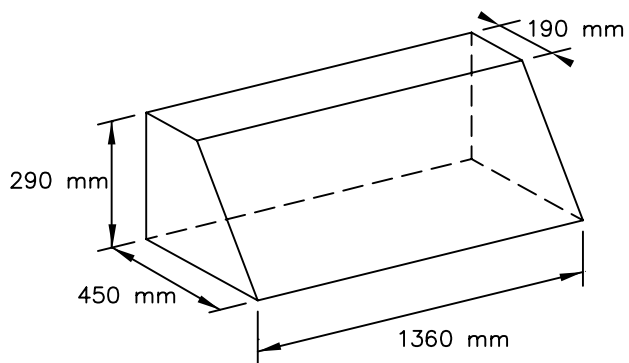
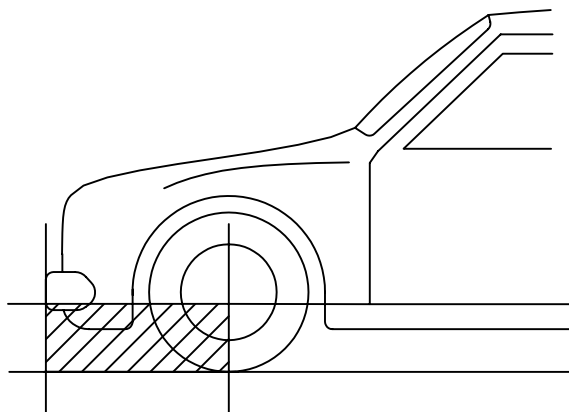

Dessin/Drawing 279-4

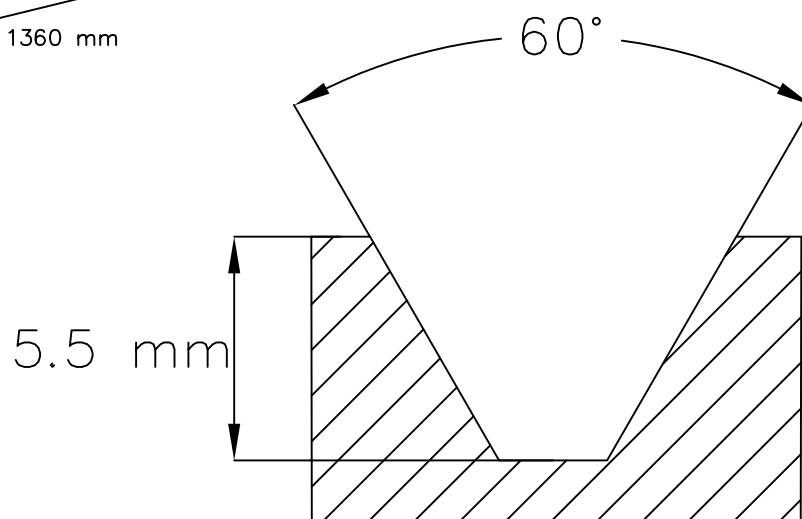

Dessin/Drawing 279-5

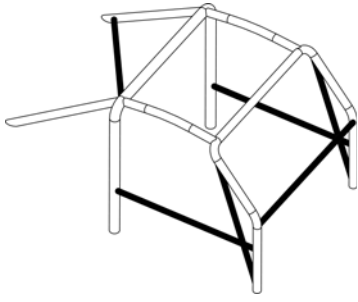

Dessin/Drawing 283-1A

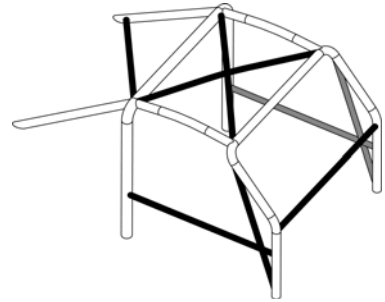

Dessin/Drawing 283-1B

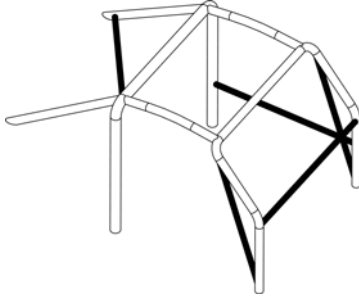

Dessin/Drawing 283-2A

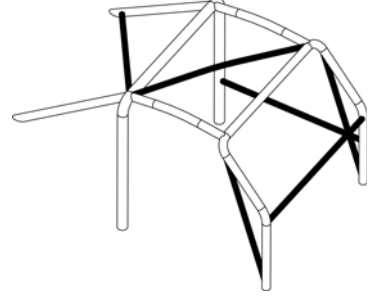

Dessin/Drawing 283-2B

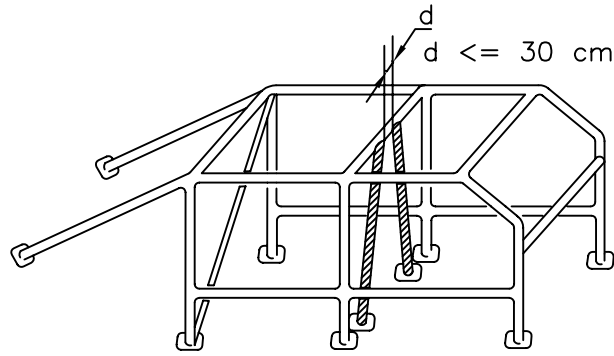

Dessin/Drawing 283-3

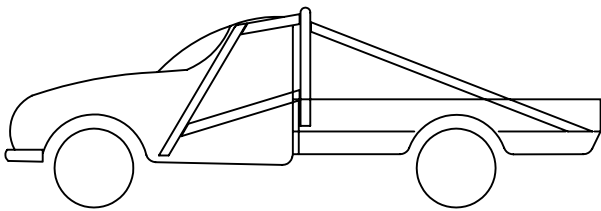

Dessin/Drawing 283-4

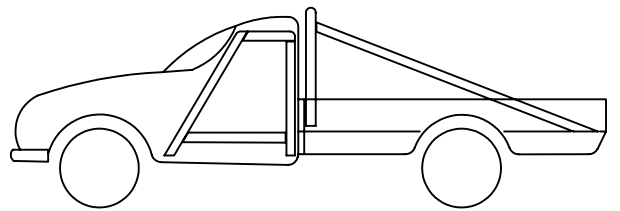

Dessin/Drawing 283-5

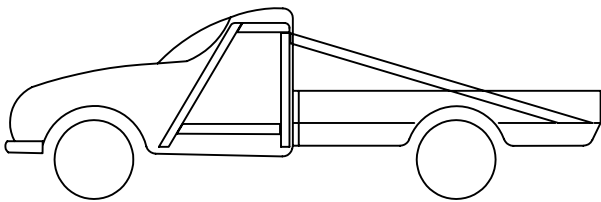

Dessin/Drawing 283-6

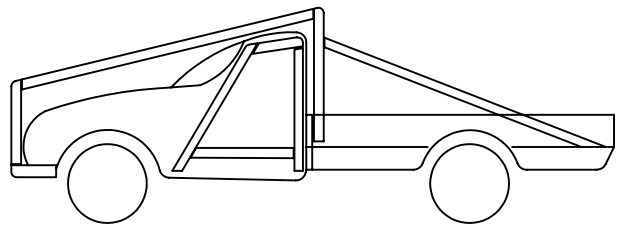

Dessin/Drawing 283-7

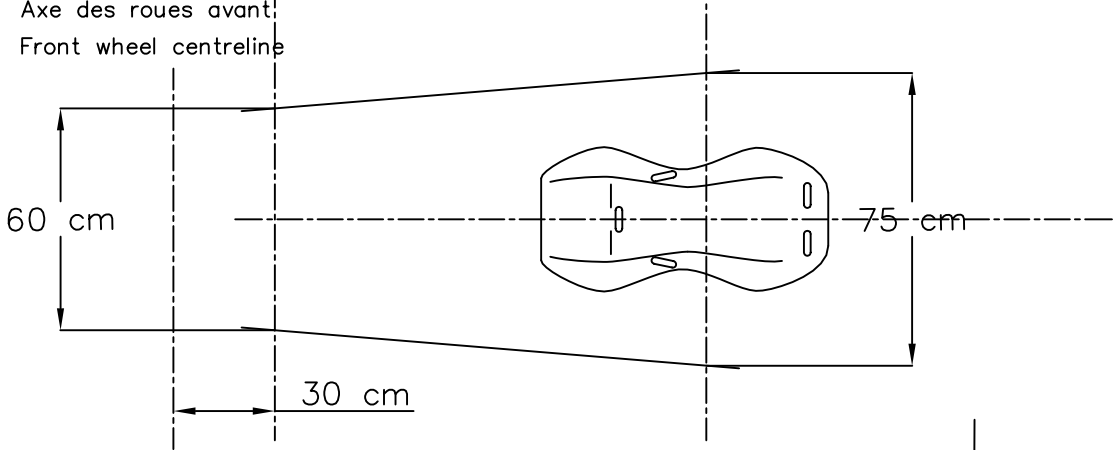
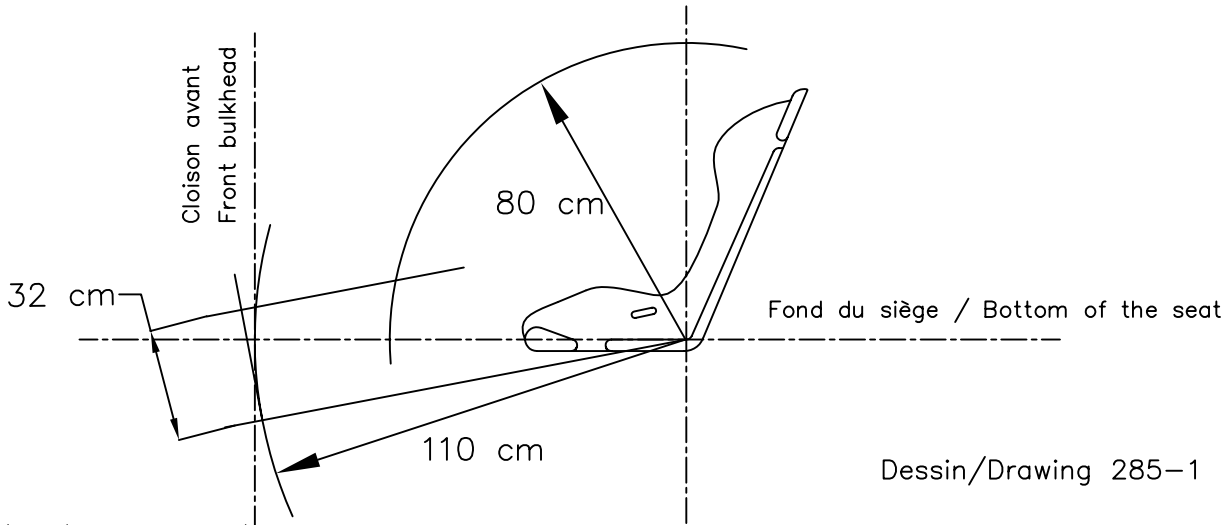

Position de l'ancrage inférieur de l'amortisseur
Position of the lower mounting point of the shock absorber

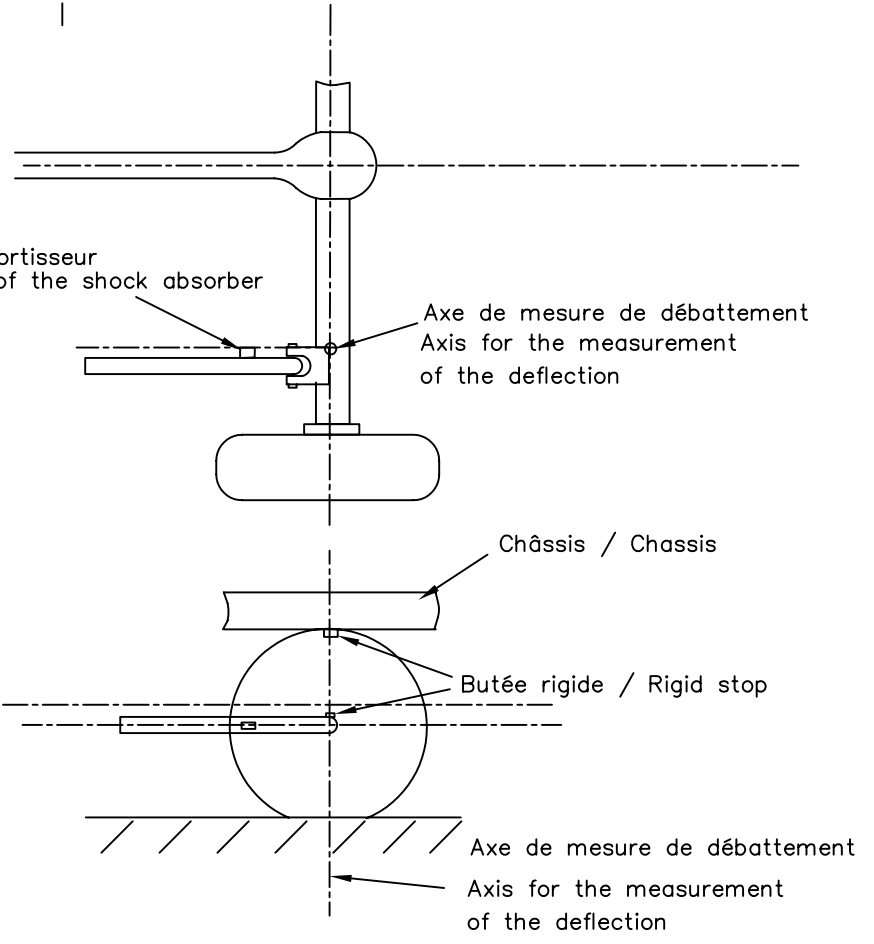

Dessin/Drawing 285-2

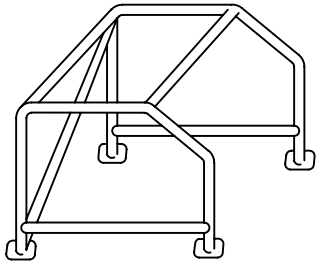

Dessin/Drawing 287-1

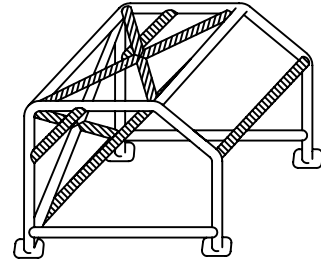

Dessin/Drawing 287-2

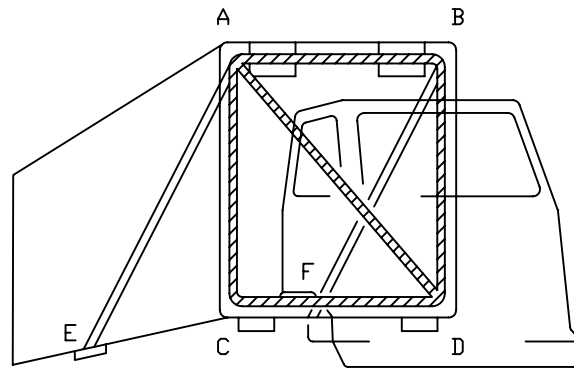

Dessin/Drawing 287-3

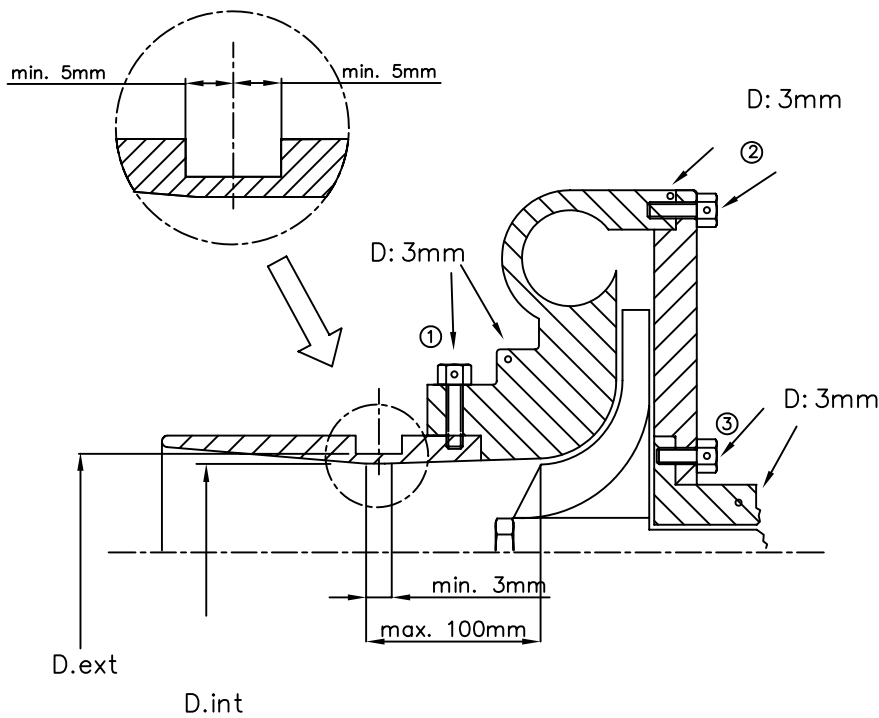

- ① Trou pour bride ou bride/carter de compression
Hole for restrictor or restrictor/compressor housing
- ② Trou pour carter de compression ou carter/flasque
Hole for compressor housing or housing/flange
- ③ Trou pour carter de turbine carter/flasque
Hole for turbine housing or housing/flange

Dessin/Drawing 287-4

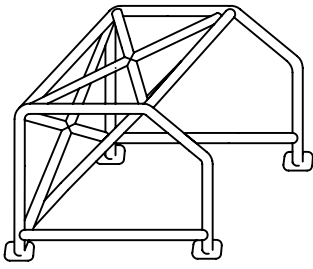

Dessin/Drawing 290-1

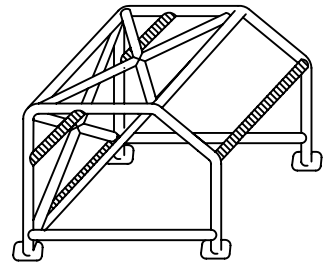

Dessin/Drawing 290-2

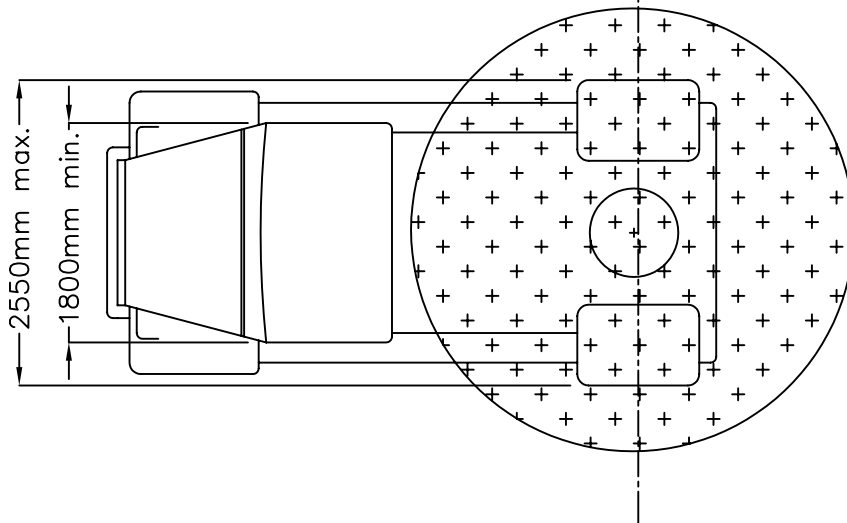
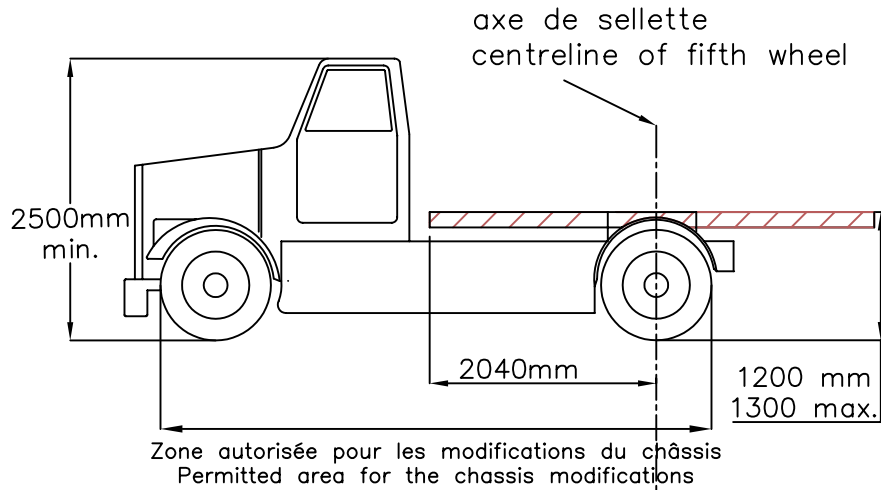

Dessin/Drawing 290-3

120mm max. à l'extérieur de la poutre principale du châssis
 120mm max. from the outer surface of the chassis rail

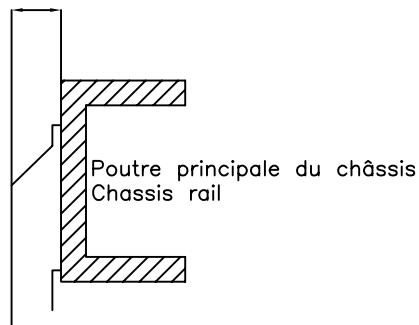

Dessin/Drawing 290-4

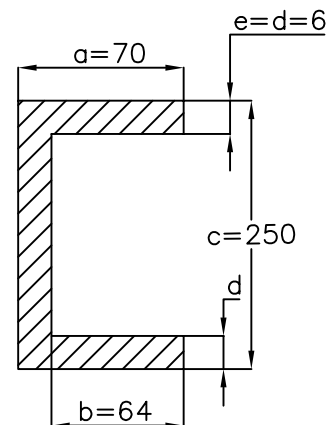

Dessin/Drawing 290-5

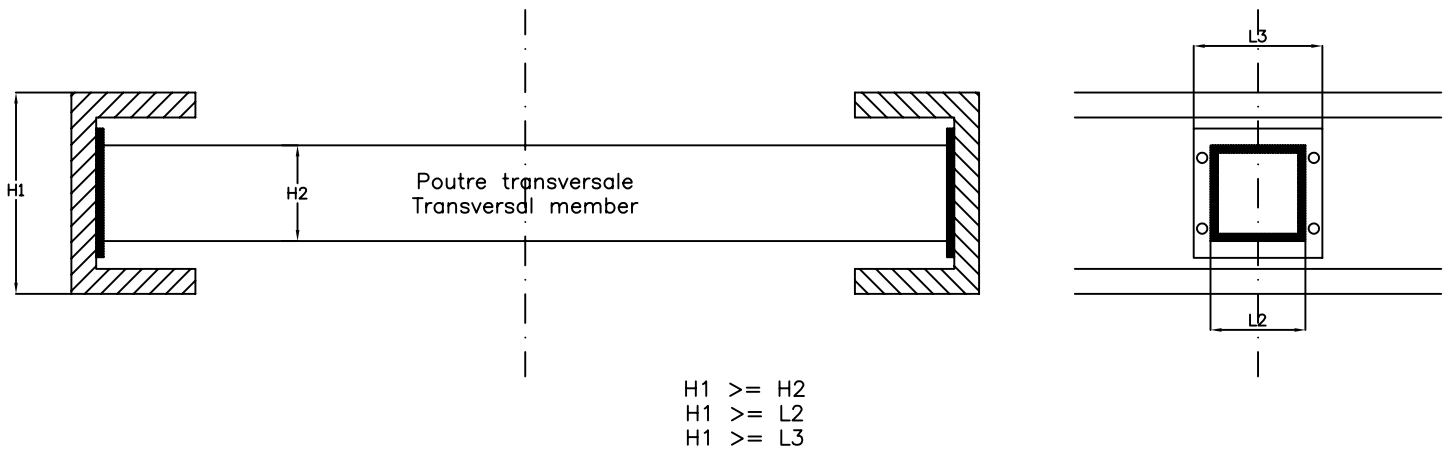

Dessin/Drawing 290-6

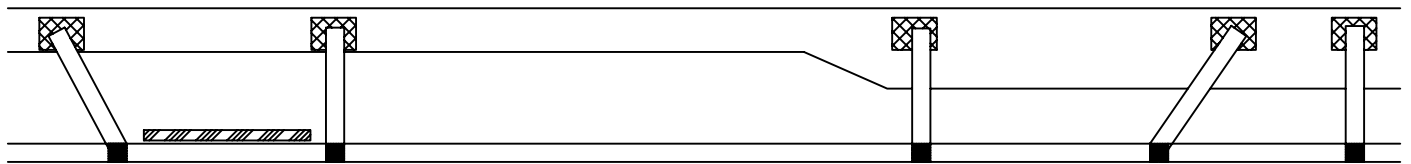
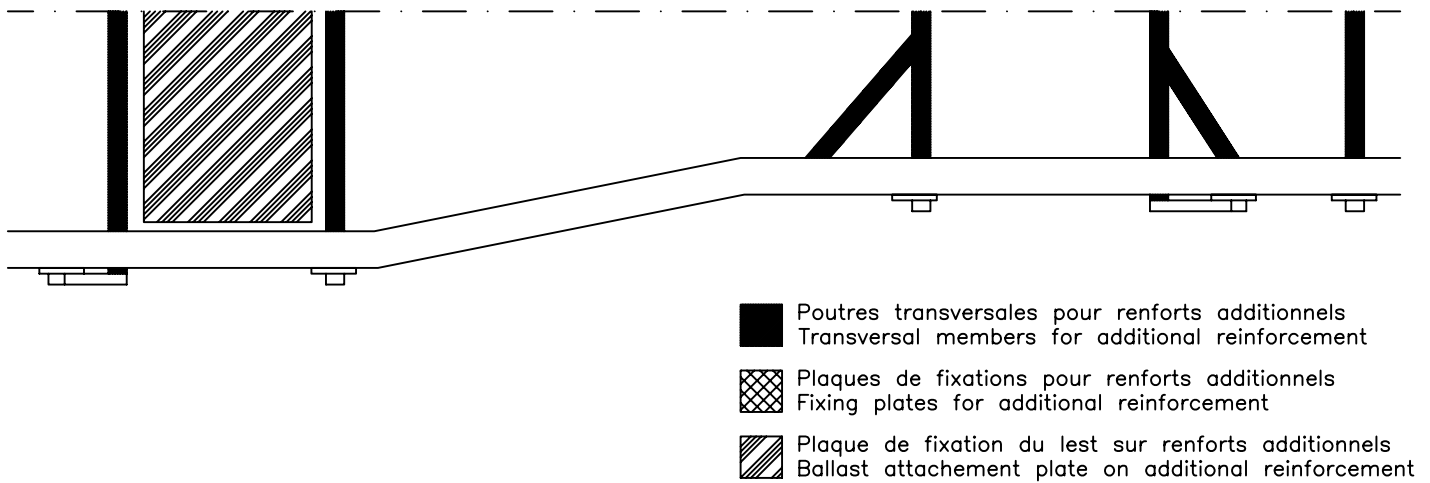

Dessin/Drawing 290-7

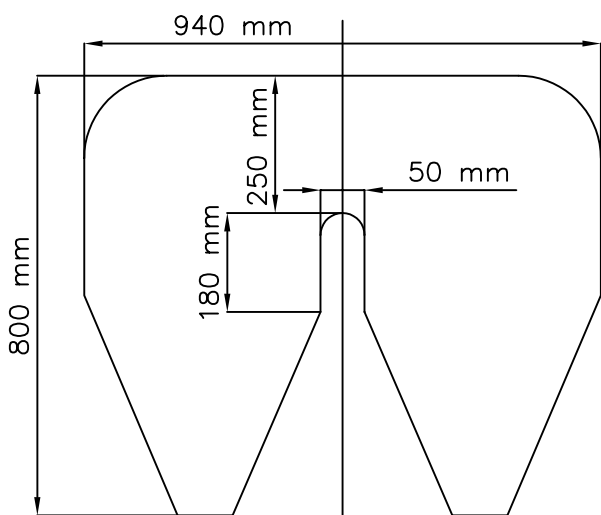

Dessin/Drawing 290-8

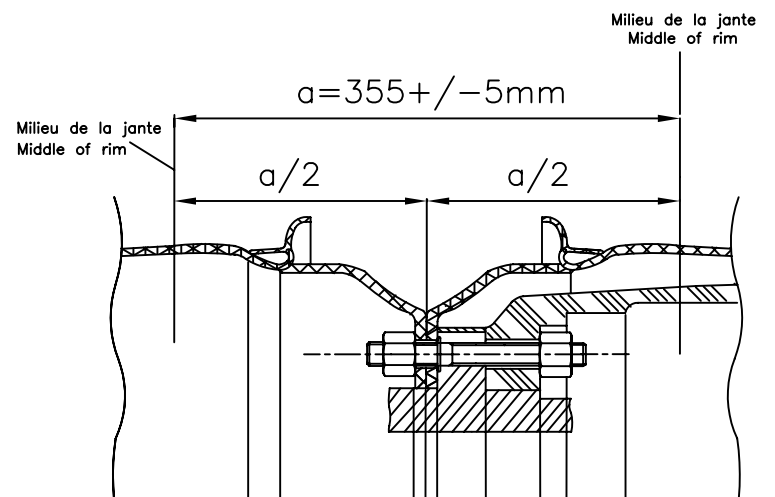

Dessin/Drawing 290-9